

TA7402P

T-77-05-05

AM TUNER IC FOR CAR RADIO

The TA7402P is AM tuner IC with high performance, especially excellent overload characteristic, for car radio applications.

This IC is also suitable for AM stereo decoder, because of excellent AGC and IF output Terminal.

- Function : RF Amplifer, Mixer, Local OSG, IF Amplifer, Detector, AGC
- Small Package :
ZIP (Zigzag In-line Package) 16 pin
- Wide Supply Voltage Range :
VCC=7 ~ 15V
Recommended Voltage ; VCC=9V

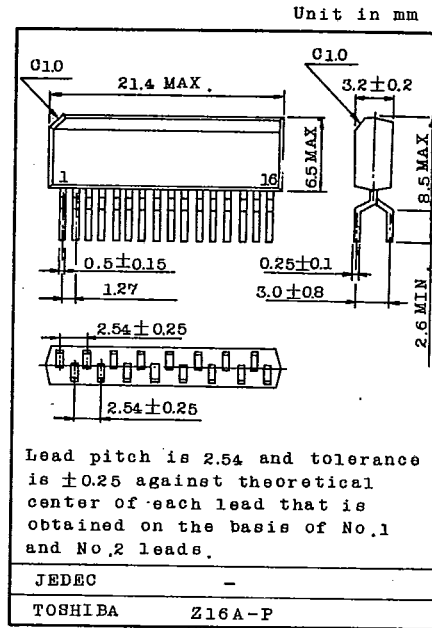

MAXIMUM RATINGS (Ta=25°C)

CHARACTERISTIC	SYMBOL	RATING	UNIT
Supply Voltage	VCC	16	V
Power Dissipation (Note)	PD	675	mW
Operating Temperature	Topr	-30 ~ 75	°C
Storage Temperature	Tstg	-55 ~ 150	°C

Note: Derated above Ta=25°C in the proportion of 5.4mW/°C.

ELECTRICAL CHARACTERISTICS

(Unless otherwise specified, $V_{CC}=9V$, $f_S=1MHz$, $f_M=400Hz$, Mode=30%, $IF=455kHz$, $T_a=25^{\circ}C$)

CHARACTERISTIC		SYMBOL	TEST CIR-CUIT	TEST CONDITION	MIN.	TYP.	MAX.	UNIT
Supply Current		I_{CC}	1	6 Pin Open	9	13	20	mA
Recovered Output Voltage		V_{OD}	1	$V_{IN}=74dB_{\mu V}$	65	90	115	mV _{rms}
Maximum Sensitivity		MS	1	$V_{OD}=20mV_{rms}$	-	9	-	dB μV
Quieting Sensitivity		QS	1	S/N=20dB	-	24	30	dB μV
Signal to Noise Ratio		S/N	1	$V_{IN}=74dB_{\mu V}$	46	52.5	-	dB
Total Harmonic Distortion		THD(1)	1	$V_{IN}=74dB_{\mu V}$	-	0.3	3	%
		THD(2)	1	$V_{IN}=74dB_{\mu V}$ Mod=80%	-	0.6	-	
		THD(3)	1	$V_{IN}=120dB_{\mu V}$	-	0.5	-	
Tweet		Tweet	1	$V_{IN}=74dB_{\mu V}$ Max. Point	2IF 3IF	- -37 -50	- - -	dB
Pin 15 Input Impedance	Parallel Input Resistance	R_{ip15}	2	$f=1000kHz$	-	6.6	-	k Ω
	Parallel Input Capacitance	C_{ip15}			-	3	-	pF
Pin 13 Output Impedance	Parallel Output Resistance	R_{op13}	3	$f=1000kHz$	-	100	-	k Ω
	Parallel Output Capacitance	C_{op13}			-	1.4	-	pF
Pin 11 Input Impedance	Parallel Input Resistance	R_{ip11}	4	$f=1000kHz$	-	1.1	-	k Ω
	Parallel Input Capacitance	C_{ip11}			-	7.5	-	pF
Pin 9 Output Impedance	Parallel Output Resistance	R_{op9}	5	$f=455kHz$	-	100	-	k Ω
	Parallel Output Capacitance	C_{op9}			-	3.5	-	pF
Pin 7 Input Impedance	Parallel Input Resistance	R_{ip7}	6	$f=455kHz$	-	3.5	-	k Ω
	Parallel Input Capacitance	C_{ip7}			-	8	-	pF
IF Output Voltage		V_{IF1}	1	$V_{IN}=34dB_{\mu V}$	-	14	-	mV _{rms}
		V_{IF2}		$V_{IN}=74dB_{\mu V}$	-	76	-	

BLOCK DIAGRAM/TEST CIRCUIT

1. ICC, VDD, MS, QS, S/N, THD, Tweet

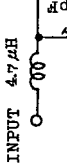
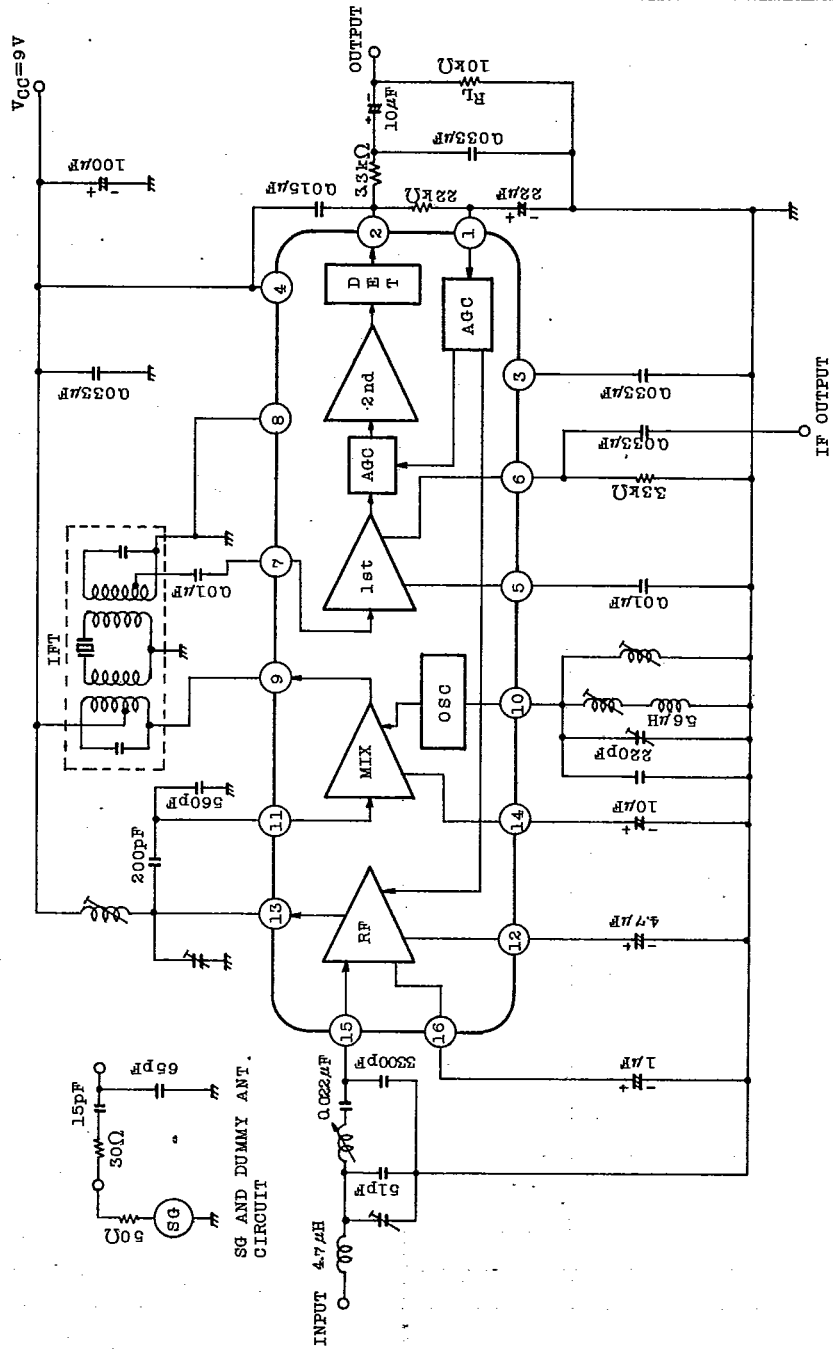

== AUDIO LINEAR IC ==

TA7402P

T-77-05-05

COIL DATA

1. OSC COIL "L"

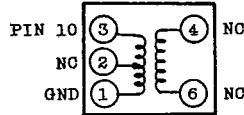

L=220μH STANDARD		
Q ≥ 80 at 796kHz		
①~② 10T	①~③ 98T	④~⑥ 39T

DENKEN Co., 4691 OR EQUIVALENT

2. IFT

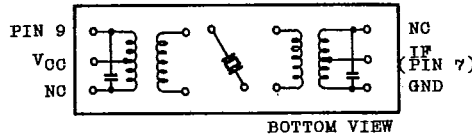

TOKO Co.,
CFT-455A OR EQUIVALENT IFT
CENTER FREQUENCY 455±3.5kHz

3. AM TUNER COIL

MITSUMI Co., CMM ZT-02 OR EQUIVALENT TUNER COIL

TUNING FREQUENCY RANGE 520 ~ 1660±40kHz

1. DC CHARACTERISTICS (VCC=9V, Terminal Voltage at No Signal)

TERMINAL No.	ITEM	SYMBOL	TYP.	UNIT
1	AGC Input	V1	2.0	V
2	Recovered Output	V2	2.0	V
3	2nd IF Bypass	V3	2.6	V
4	VCC	V4	9.0	V
5	1st IF Bypass	V5	2.6	V
6	IF Output	V6	2.5	V
7	IF Input	V7	2.6	V
8	GND	V8	-	V
9	Mix Output	V9	9.0	V
10	Local OSC	V10	-	V
11	Mix Input	V11	4.3	V
12	AGC Bypass	V12	4.8	V
13	RF Output	V13	9.0	V
14	Mix Bypass	V14	4.3	V
15	RF Input	V15	2.0	V
16	RF Bypass	V16	1.3	V

2. Rip15, Cip15

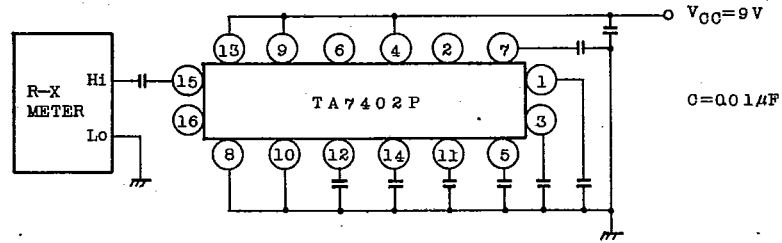

3. Rop13, Cop13

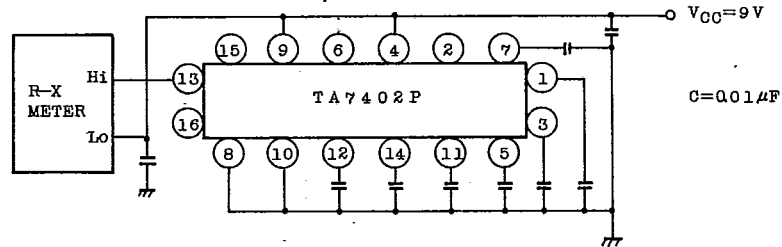

4. Rip11, Cip11

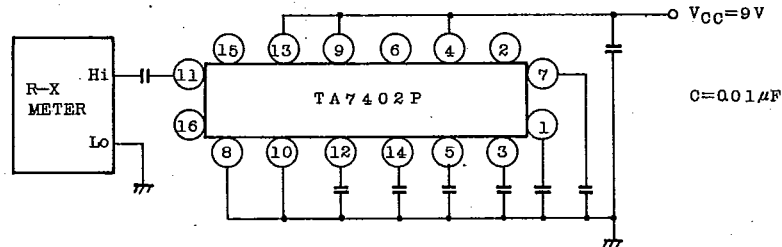

5. Rop9, Cop9

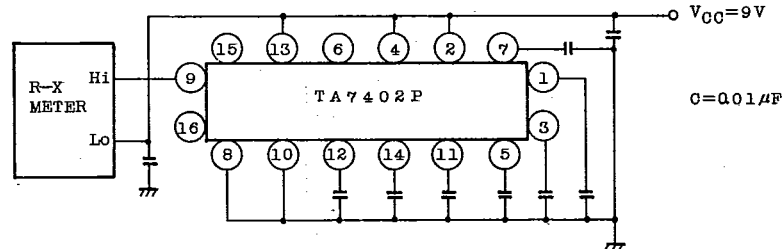

6. Rip7, Cip7

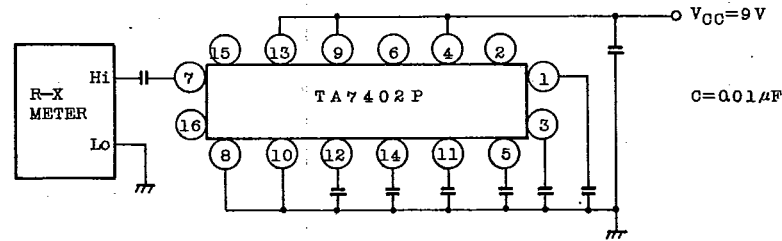

TA7402P

T-77-05-05

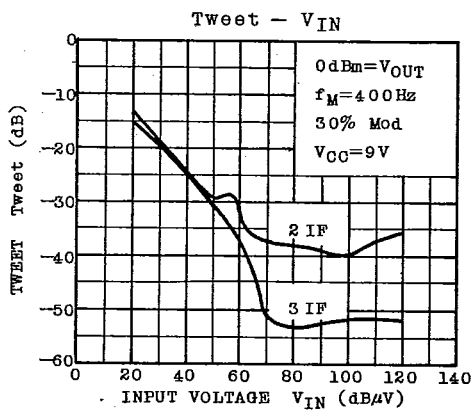
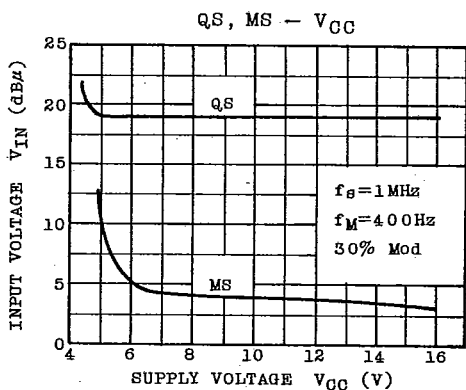
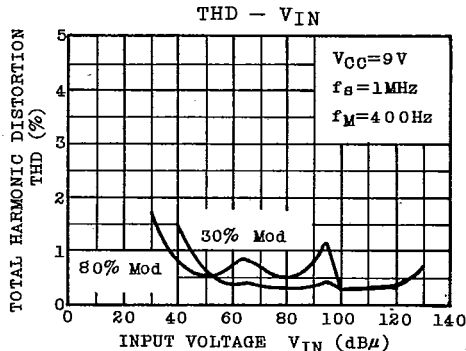
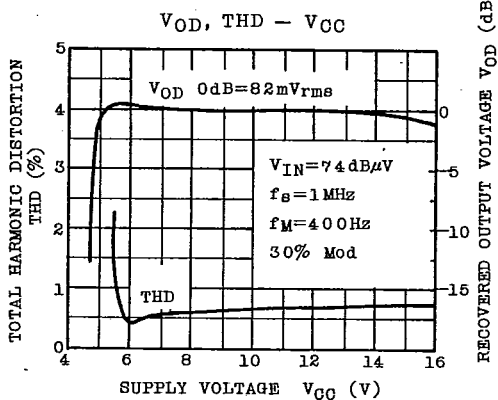
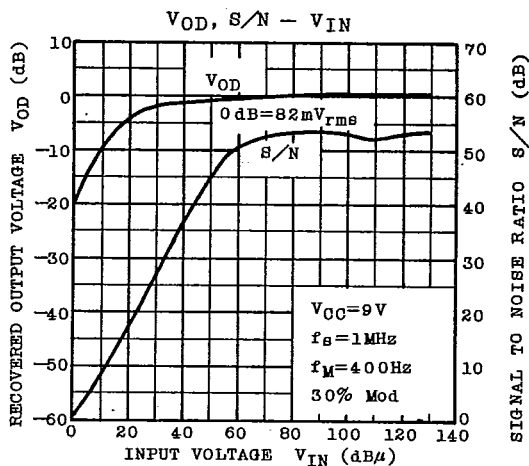
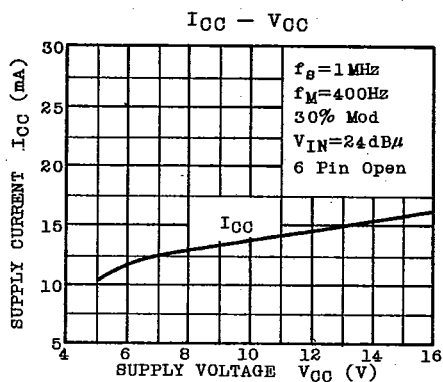

The tweet is defined as follow
 $0\text{dB} = V_{OD}$ at Mod=30%, $f_M=400\text{Hz}$

TA7402P

T-77-05-05

IF REJECTION RATIO,
IMAGE REJECTION RATIO
QS, MS, VOD - f

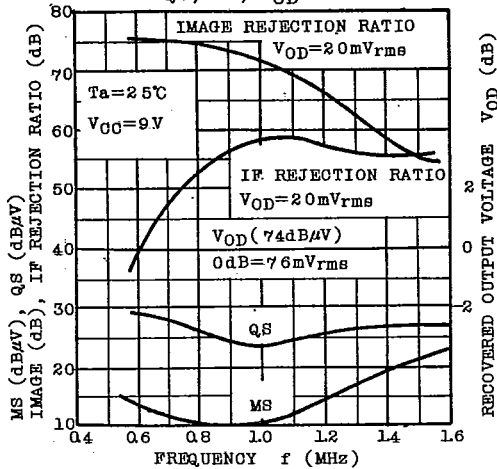

2 SIGNAL CHARACTERISTIC
-3dB SIGNAL SUPPRESSION EFFECT

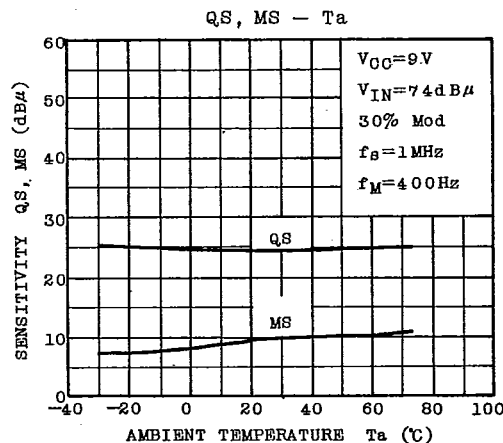
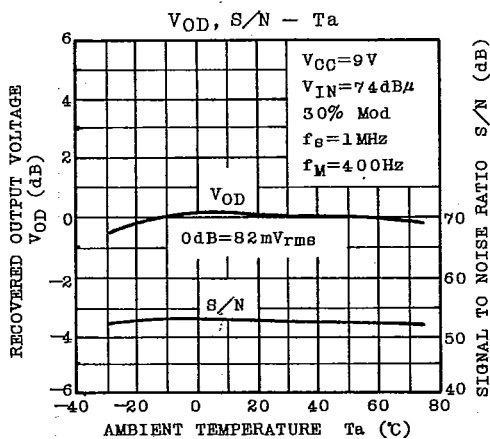
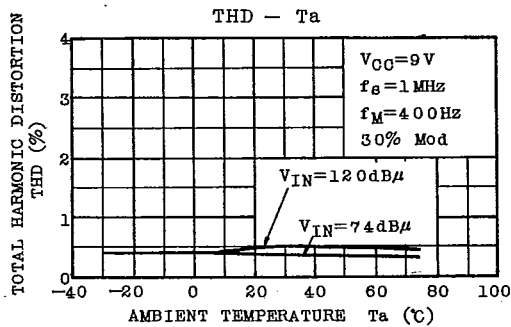
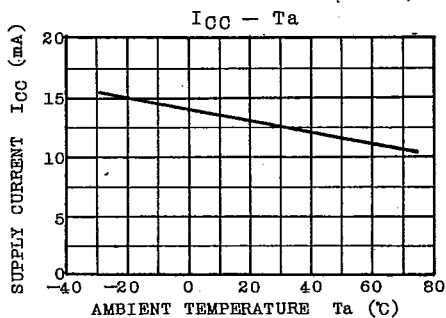
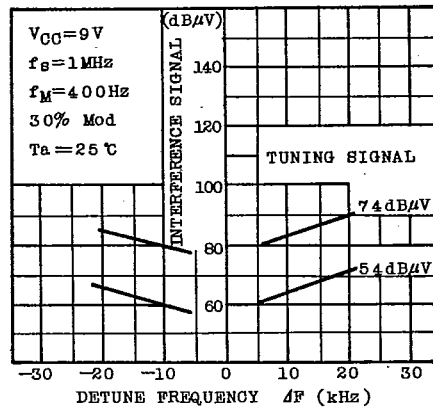

AUDIO LINEAR IC

APPLICATION CIRCUIT

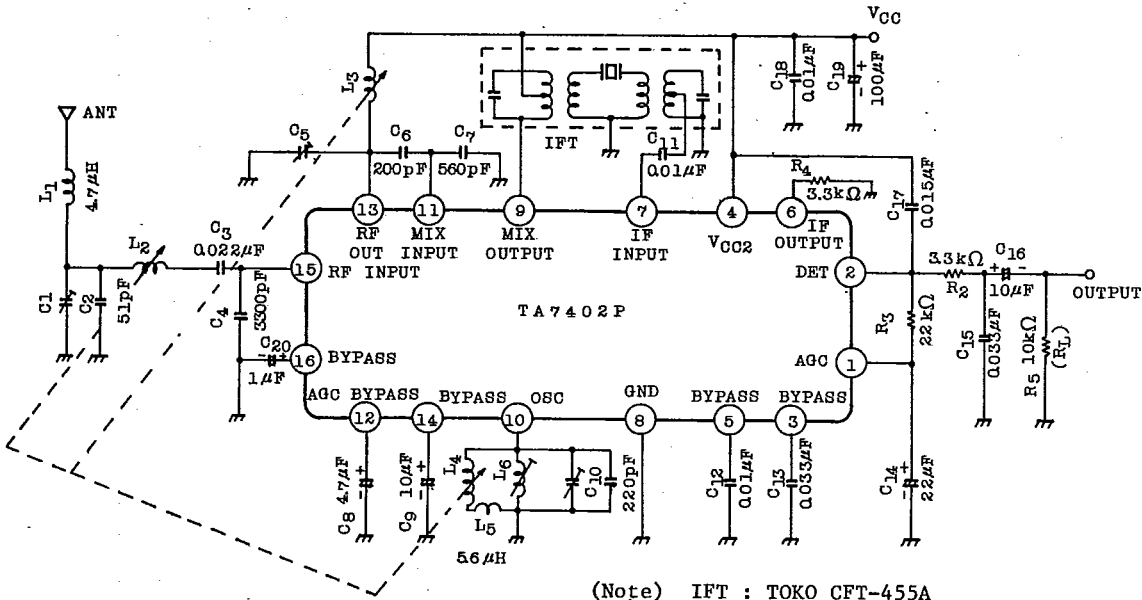

(Note) IFT : TOKO CFT-455A

Note :

1. To avoid the instability (especially tweet problem), capacitor C17 must be placed near by 2 pin and 4 pin.
2. Inductor L1 is the noise radiation suppressor from antenna.
3. Capacitor C6 and C7 must be selected so that the injection level of the mixer stage will be optimum value.
4. AGC by-passing capacitor C14 and C8 determine AGC response speed. So, large value will cause slow response and too small value will cause poor distortion characteristics at low frequency.
5. When the output is not used, the terminal 6 could be open.

EXTERNAL PARTS TABLE

PARTS No.	TYPICAL	PURPOSE	INFLUENCE		NOTE
			SMALLER THAN TYP.	GREATER THAN TYP.	
C3	0.022 μ F	ANT Tuning Circuit	Decrease in ANT gain	Increase in ANT gain	
C4	3300pF	ANT Tuning Circuit	Degradation in quieting sensitivity Increase in ANT gain	Improvement in quieting sensitivity Decrease in ANT gain	Low temperature drift capacitor should be required
C6	200pF	RF Tuning and Coupling	Decrease in gain	Increase in gain	
C7	560pF	Coupling Divider	Increase in gain	Decrease in gain	
C8	4.7 μ F	RF AGC Bypass	Degradation of THD at high level input	Poor AGC response	
C9	10 μ F	Mix Bypass	Decrease in gain	-	
C11	0.01 μ F	Coupling Capacitor	Decrease in gain	-	
C12	0.01 μ F	IF Bypass	Decrease in gain	-	
C13	0.033 μ F	IF Bypass	Decrease in gain	-	
C14	22 μ F	AGC Ripple Filter & Time Constant	Degradation of THD at low f_m input	Poor AGC response	
C15	0.033 μ F	Part of Low Pass Filter (R2, C15)	Degradation of S/N	Poor frequency response at higher frequency	
C17	0.015 μ F	Detector Circuit	Degradation of S/N Instability with IF leak	Decrease in recovered output voltage	
C18	0.01 μ F	Decoupling	Decrease in filter effect	-	
C19	100 μ F	Decoupling	Load to Motorboating	-	
C20	1 μ F	RF Bypass	Poor quieting sensitivity	Poor cross-modulation characteristics	
R2	3.3k Ω	Part of Low Pass Filter (R2, C15)	Degradation of S/N	Poor frequency response at higher frequency	
R3	22k Ω	AGC Ripple Filter & Time Constant	Degradation of THD at low f_m input	Poor AGC response	
R4	3.3k Ω	IF Output Load	Degradation of tweet	-	