

LM7905,LM7912,LM7915

LM79XX Series 3-Terminal Negative Regulators



Literature Number: SNOSBQ7B

LM79XX Series 3-Terminal Negative Regulators

General Description

The LM79XX series of 3-terminal regulators is available with fixed output voltages of $-5V$, $-12V$, and $-15V$. These devices need only one external component—a compensation capacitor at the output. The LM79XX series is packaged in the TO-220 power package and is capable of supplying 1.5A of output current.

These regulators employ internal current limiting safe area protection and thermal shutdown for protection against virtually all overload conditions.

Low ground pin current of the LM79XX series allows output voltage to be easily boosted above the preset value with a

resistor divider. The low quiescent current drain of these devices with a specified maximum change with line and load ensures good regulation in the voltage boosted mode.

For applications requiring other voltages, see LM137 datasheet.

Features

- Thermal, short circuit and safe area protection
- High ripple rejection
- 1.5A output current
- 4% tolerance on preset output voltage

Connection Diagram

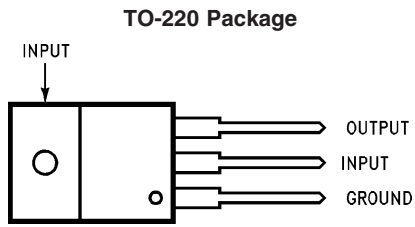

00734014

Front View

Order Number LM7905CT, LM7912CT or LM7915CT
See NS Package Number TO3B

*Required if regulator is separated from filter capacitor by more than 3". For value given, capacitor must be solid tantalum. 25 μ F aluminum electrolytic may be substituted.

†Required for stability. For value given, capacitor must be solid tantalum. 25 μ F aluminum electrolytic may be substituted. Values given may be increased without limit.

For output capacitance in excess of 100 μ F, a high current diode from input to output (1N4001, etc.) will protect the regulator from momentary input shorts.

Typical Applications

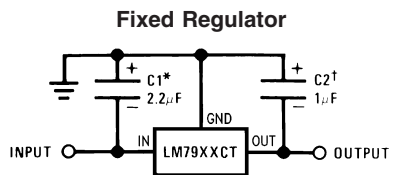

00734003

Absolute Maximum Ratings (Note 1)

If Military/Aerospace specified devices are required, please contact the National Semiconductor Sales Office/Distributors for availability and specifications.

Input Voltage	($V_o = -5V$)	-25V	($V_o = -5V$)	25V
	($V_o = -12V$ and $-15V$)	-35V	($V_o = -12V$ and $-15V$)	30V
Input-Output Differential			Power Dissipation (Note 2)	Internally Limited
			Operating Junction Temperature Range	0°C to +125°C
			Storage Temperature Range	-65°C to +150°C
			Lead Temperature (Soldering, 10 sec.)	230°C

Electrical Characteristics

Conditions unless otherwise noted: $I_{OUT} = 500mA$, $C_{IN} = 2.2\mu F$, $C_{OUT} = 1\mu F$, $0^\circ C \leq T_J \leq +125^\circ C$, Power Dissipation $\leq 1.5W$.

Part Number			LM7905C			Units	
Output Voltage			-5V				
Input Voltage (unless otherwise specified)			-10V				
Symbol	Parameter	Conditions	Min	Typ	Max		
V_o	Output Voltage	$T_J = 25^\circ C$	-4.8	-5.0	-5.2	V	
		$5mA \leq I_{OUT} \leq 1A$,	-4.75		-5.25	V	
		$P \leq 15W$				V	
ΔV_o	Line Regulation	$T_J = 25^\circ C$, (Note 3)		8	50	mV	
							V
				2	15	mV	
							V
ΔV_o	Load Regulation	$T_J = 25^\circ C$, (Note 3)		15	100	mV	
				5	50	mV	
I_Q	Quiescent Current	$T_J = 25^\circ C$		1	2	mA	
ΔI_Q	Quiescent Current Change	With Line			0.5	mA	
		With Load, $5mA \leq I_{OUT} \leq 1A$			0.5	mA	
V_n	Output Noise Voltage	$T_A = 25^\circ C$, $10Hz \leq f \leq 100Hz$		125		μV	
			Ripple Rejection	$f = 120Hz$	54	66	dB
	Dropout Voltage	$T_J = 25^\circ C$, $I_{OUT} = 1A$		1.1		V	
I_{OMAX}	Peak Output Current	$T_J = 25^\circ C$		2.2		A	
			Average Temperature Coefficient of Output Voltage	$I_{OUT} = 5mA$, $0^\circ C \leq T_J \leq 100^\circ C$		0.4	

Electrical Characteristics

Conditions unless otherwise noted: $I_{OUT} = 500mA$, $C_{IN} = 2.2\mu F$, $C_{OUT} = 1\mu F$, $0^\circ C \leq T_J \leq +125^\circ C$, Power Dissipation $\leq 1.5W$.

Part Number			LM7912C			LM7915C			Units	
Output Voltage			-12V			-15V				
Input Voltage (unless otherwise specified)			-19V			-23V				
Symbol	Parameter	Conditions	Min	Typ	Max	Min	Typ	Max		
V_o	Output Voltage	$T_J = 25^\circ C$	-11.5	-12.0	-12.5	-14.4	-15.0	-15.6	V	
		$5mA \leq I_{OUT} \leq 1A$,	-11.4		-12.6	-14.25		-15.75	V	
		$P \leq 15W$							V	
ΔV_o	Line Regulation	$T_J = 25^\circ C$, (Note 3)		5	80		5	100	mV	
										V
				3	30		3	50	mV	
										V

Electrical Characteristics (Continued)

Conditions unless otherwise noted: $I_{OUT} = 500\text{mA}$, $C_{IN} = 2.2\mu\text{F}$, $C_{OUT} = 1\mu\text{F}$, $0^\circ\text{C} \leq T_J \leq +125^\circ\text{C}$, Power Dissipation $\leq 1.5\text{W}$.

Part Number			LM7912C			LM7915C			Units
Output Voltage			-12V			-15V			
Input Voltage (unless otherwise specified)			-19V			-23V			
Symbol	Parameter	Conditions	Min	Typ	Max	Min	Typ	Max	
ΔV_O	Load Regulation	$T_J = 25^\circ\text{C}$, (Note 3)							
		$5\text{mA} \leq I_{OUT} \leq 1.5\text{A}$		15	200		15	200	mV
		$250\text{mA} \leq I_{OUT} \leq 750\text{mA}$		5	75		5	75	mV
I_Q	Quiescent Current	$T_J = 25^\circ\text{C}$		1.5	3		1.5	3	mA
ΔI_Q	Quiescent Current Change	With Line			0.5			0.5	mA
		$(-30 \leq V_{IN} \leq -14.5)$					$(-30 \leq V_{IN} \leq -17.5)$		V
		With Load, $5\text{mA} \leq I_{OUT} \leq 1\text{A}$			0.5			0.5	mA
V_n	Output Noise Voltage	$T_A = 25^\circ\text{C}$, $10\text{Hz} \leq f \leq 100\text{Hz}$		300			375		μV
		Ripple Rejection	$f = 120\text{Hz}$	54	70		54	70	dB
			$(-25 \leq V_{IN} \leq -15)$				$(-30 \leq V_{IN} \leq -17.5)$		V
	Dropout Voltage	$T_J = 25^\circ\text{C}$, $I_{OUT} = 1\text{A}$		1.1			1.1		V
I_{OMAX}	Peak Output Current	$T_J = 25^\circ\text{C}$		2.2			2.2		A
		Average Temperature	$I_{OUT} = 5\text{mA}$,		-0.8		-1.0		$\text{mV}/^\circ\text{C}$
		Coefficient of Output Voltage	$0^\circ\text{C} \leq T_J \leq 100^\circ\text{C}$						

Note 1: Absolute Maximum Ratings indicate limits beyond which damage to the device may occur. Operating Ratings indicate conditions for which the device is intended to be functional, but do not guarantee Specific Performance limits. For guaranteed specifications and test conditions, see the Electrical Characteristics.

Note 2: Refer to Typical Performance Characteristics and Design Considerations for details.

Note 3: Regulation is measured at a constant junction temperature by pulse testing with a low duty cycle. Changes in output voltage due to heating effects must be taken into account.

Design Considerations

The LM79XX fixed voltage regulator series has thermal overload protection from excessive power dissipation, internal short circuit protection which limits the circuit's maximum current, and output transistor safe-area compensation for reducing the output current as the voltage across the pass transistor is increased.

Although the internal power dissipation is limited, the junction temperature must be kept below the maximum specified temperature (125°C) in order to meet data sheet specifications. To calculate the maximum junction temperature or heat sink required, the following thermal resistance values should be used:

Package	Typ	Max	Typ	Max
	θ_{JC} $^\circ\text{C}/\text{W}$	θ_{JC} $^\circ\text{C}/\text{W}$	θ_{JA} $^\circ\text{C}/\text{W}$	θ_{JA} $^\circ\text{C}/\text{W}$
TO-220	3.0	5.0	60	40

Solving for T_J :

$$T_J = T_A + P_D (\theta_{JC} + \theta_{CA}) \text{ or} \\ = T_A + P_D \theta_{JA} \text{ (without heat sink)}$$

Where:

T_J = Junction Temperature

T_A = Ambient Temperature

P_D = Power Dissipation

θ_{JA} = Junction-to-Ambient Thermal Resistance

θ_{JC} = Junction-to-Case Thermal Resistance

θ_{CA} = Case-to-Ambient Thermal Resistance

θ_{CS} = Case-to-Heat Sink Thermal Resistance

θ_{SA} = Heat Sink-to-Ambient Thermal Resistance

$$P_{D\text{MAX}} = \frac{T_{J\text{MAX}} - T_A}{\theta_{JC} + \theta_{CA}} \text{ or } \frac{T_{J\text{MAX}} - T_A}{\theta_{JA}}$$

$$\theta_{CA} = \theta_{CS} + \theta_{SA} \text{ (without heat sink)}$$

Typical Applications

Bypass capacitors are necessary for stable operation of the LM79XX series of regulators over the input voltage and output current ranges. Output bypass capacitors will improve the transient response by the regulator.

The bypass capacitors, (2.2 μ F on the input, 1.0 μ F on the output) should be ceramic or solid tantalum which have good

high frequency characteristics. If aluminum electrolytics are used, their values should be 10 μ F or larger. The bypass capacitors should be mounted with the shortest leads, and if possible, directly across the regulator terminals.

High Stability 1 Amp Regulator

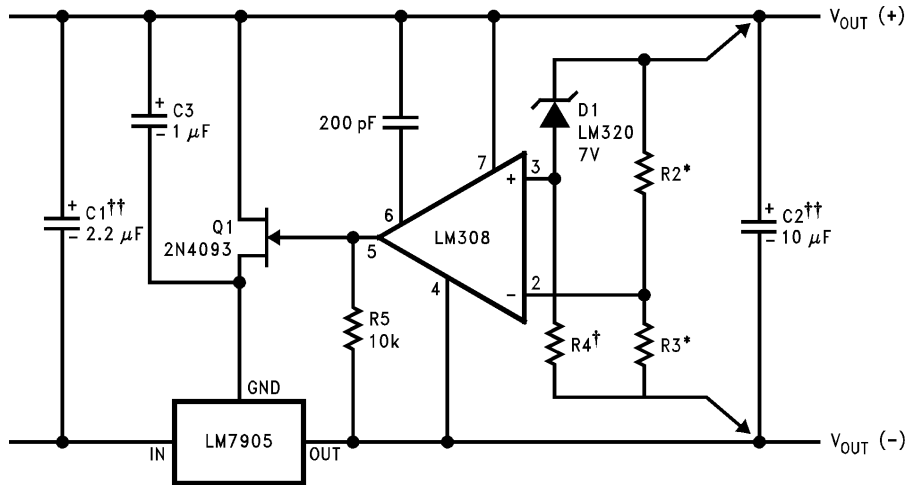

00734005

Load and line regulation < 0.01% temperature stability \leq 0.2%

†Determine Zener current

††Solid tantalum

*Select resistors to set output voltage. 2 ppm/°C tracking suggested

Current Source

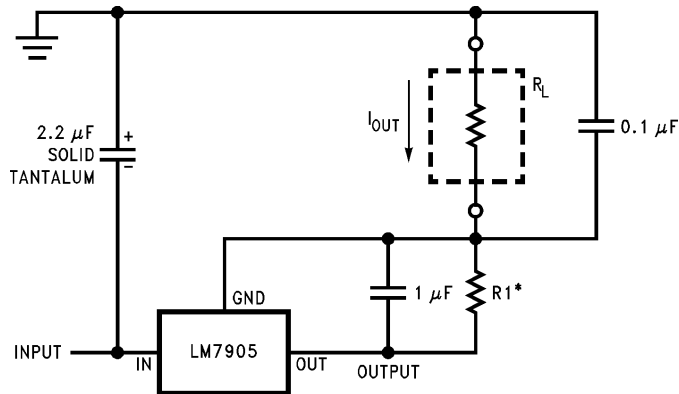

00734007

$$*I_{OUT} = 1 \text{ mA} + \frac{5V}{R1}$$

Typical Applications (Continued)

Light Controller Using Silicon Photo Cell

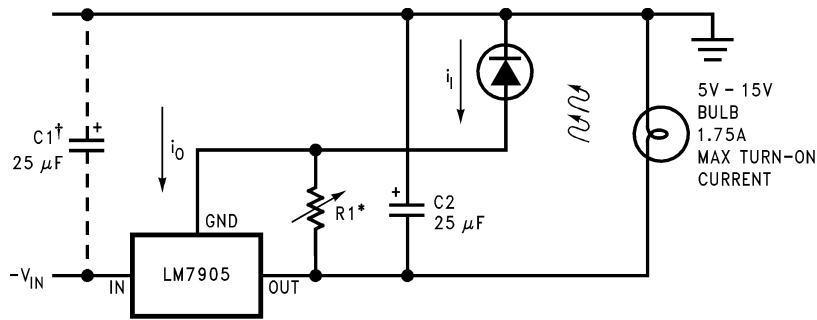

00734008

*Lamp brightness increase until $i_i = i_Q (\approx 1 \text{ mA}) + 5V/R1$.

†Necessary only if raw supply filter capacitor is more than 2" from LM7905CT

High-Sensitivity Light Controller

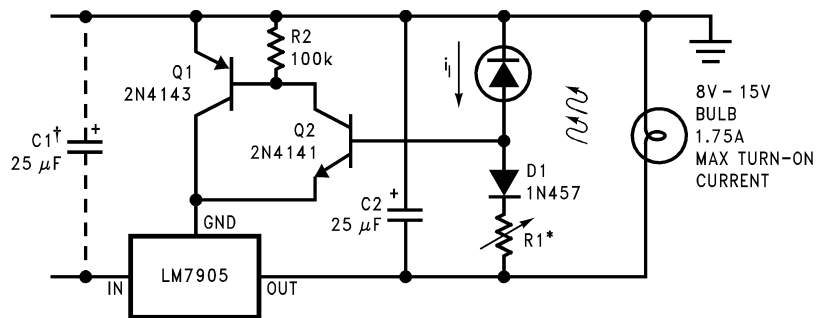

00734009

*Lamp brightness increases until $i_i = 5V/R1$ (i_i can be set as low as $1 \mu\text{A}$)

†Necessary only if raw supply filter capacitor is more than 2" from LM7905

Variable Output

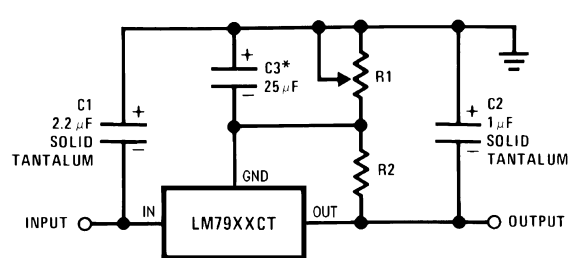

00734002

*Improves transient response and ripple rejection. Do not increase beyond $50 \mu\text{F}$.

$$V_{\text{OUT}} = V_{\text{SET}} \left(\frac{R1 + R2}{R2} \right)$$

Select R2 as follows:

LM7905CT	300Ω
LM7912CT	750Ω
LM7915CT	1k

Typical Applications (Continued)

±15V, 1 Amp Tracking Regulators

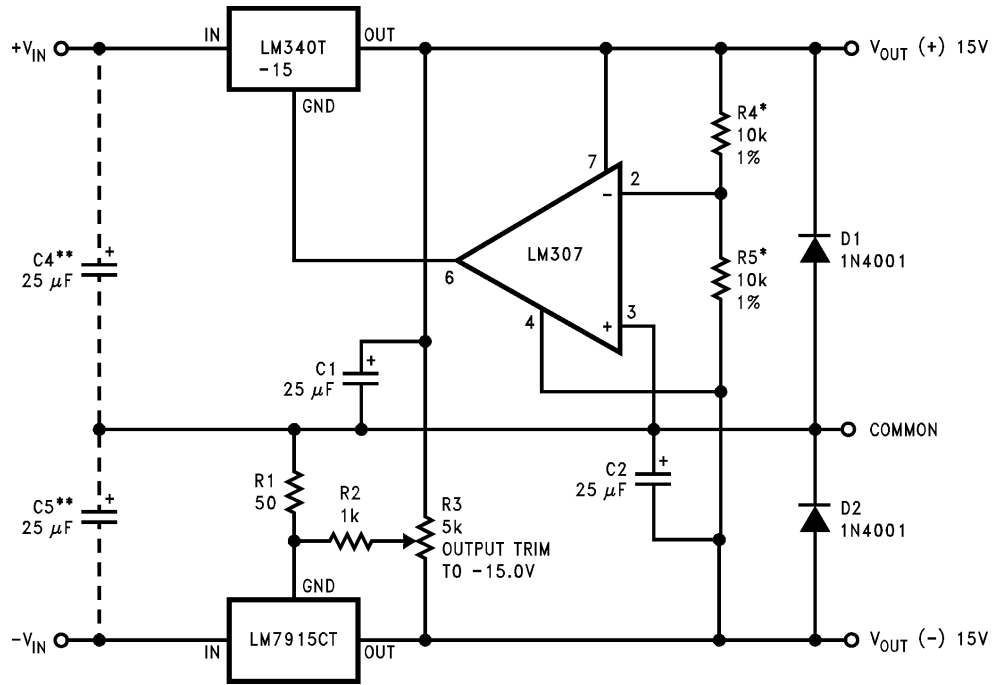

00734001

	(-15)	(+15)
Load Regulation at $\Delta I_L = 1A$	40mV	2mV
Output Ripple, $C_{IN} = 3000\mu F$, $I_L = 1A$	100 μVms	100 μVms
Temperature Stability	50mV	50mV
Output Noise $10Hz \leq f \leq 10kHz$	150 μVms	150 μVms

*Resistor tolerance of R4 and R5 determine matching of (+) and (-) outputs.

**Necessary only if raw supply filter capacitors are more than 3" from regulators.

Dual Trimmed Supply

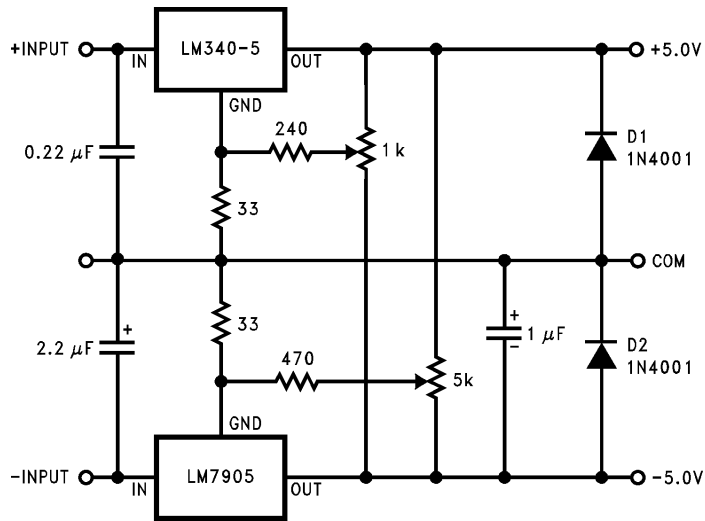

00734004

Schematic Diagrams

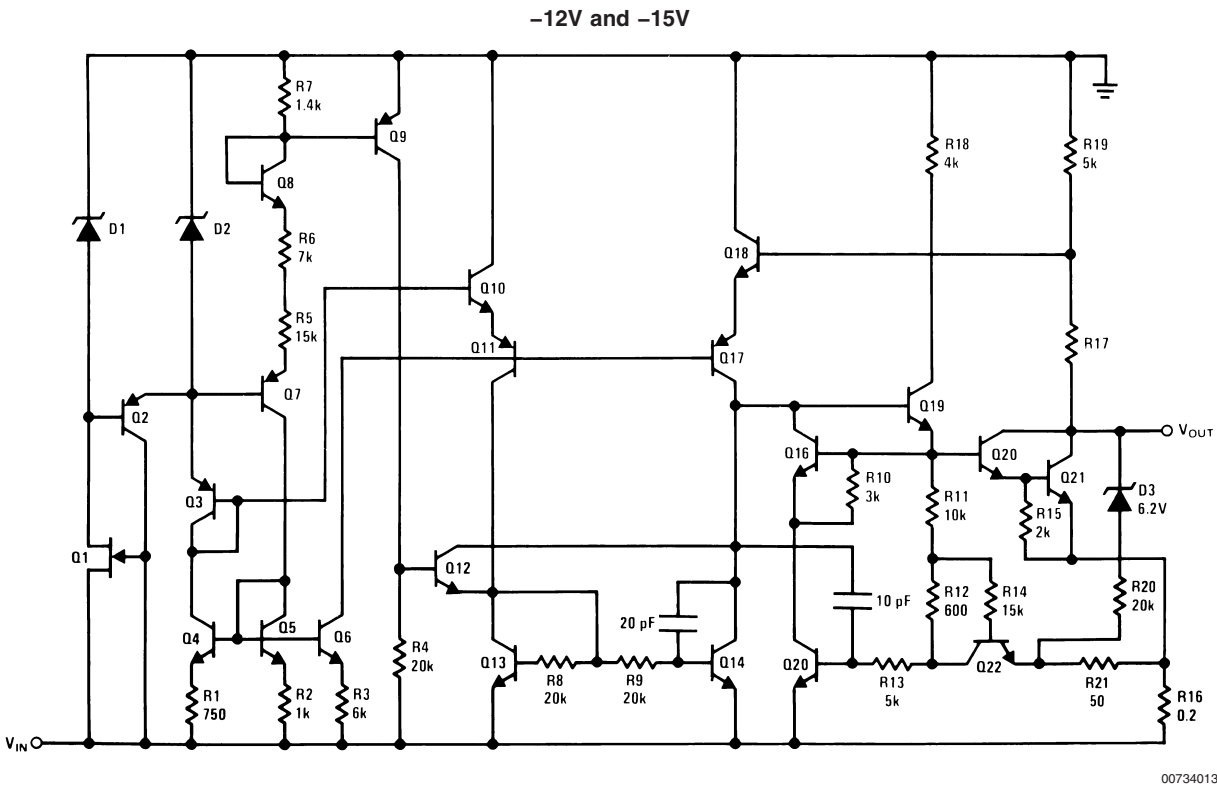
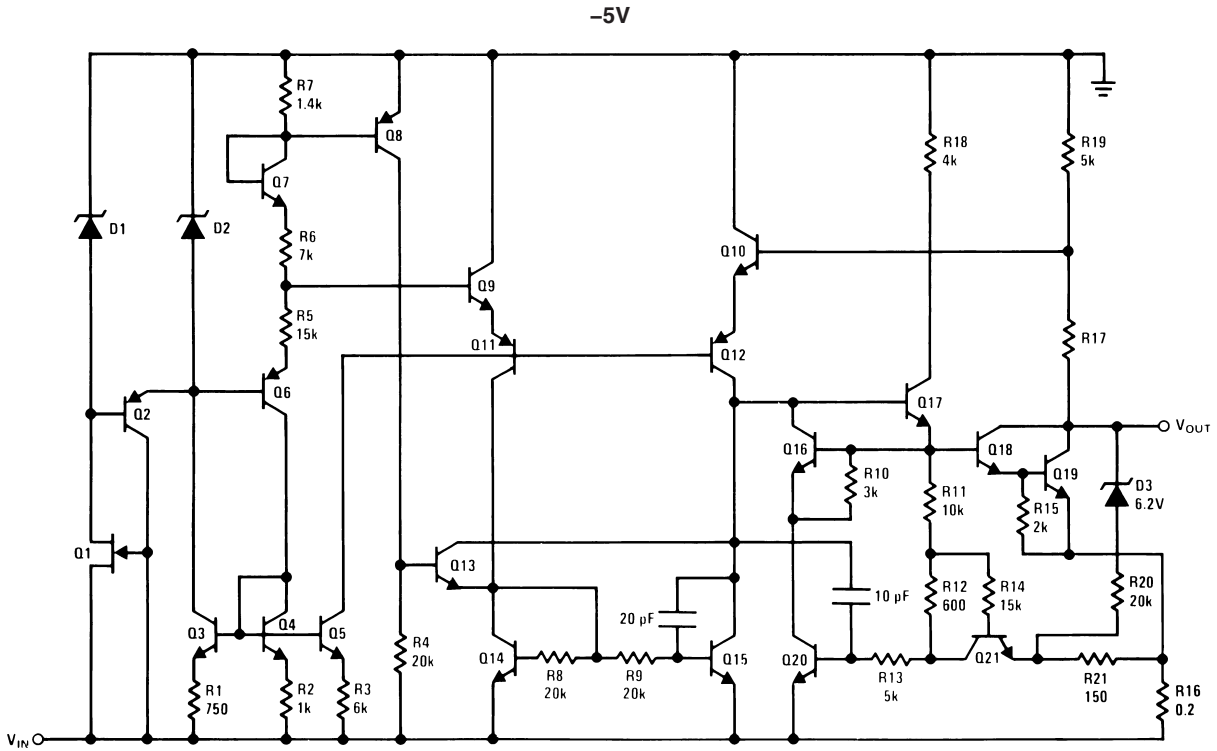

Physical Dimensions inches (millimeters)

unless otherwise noted

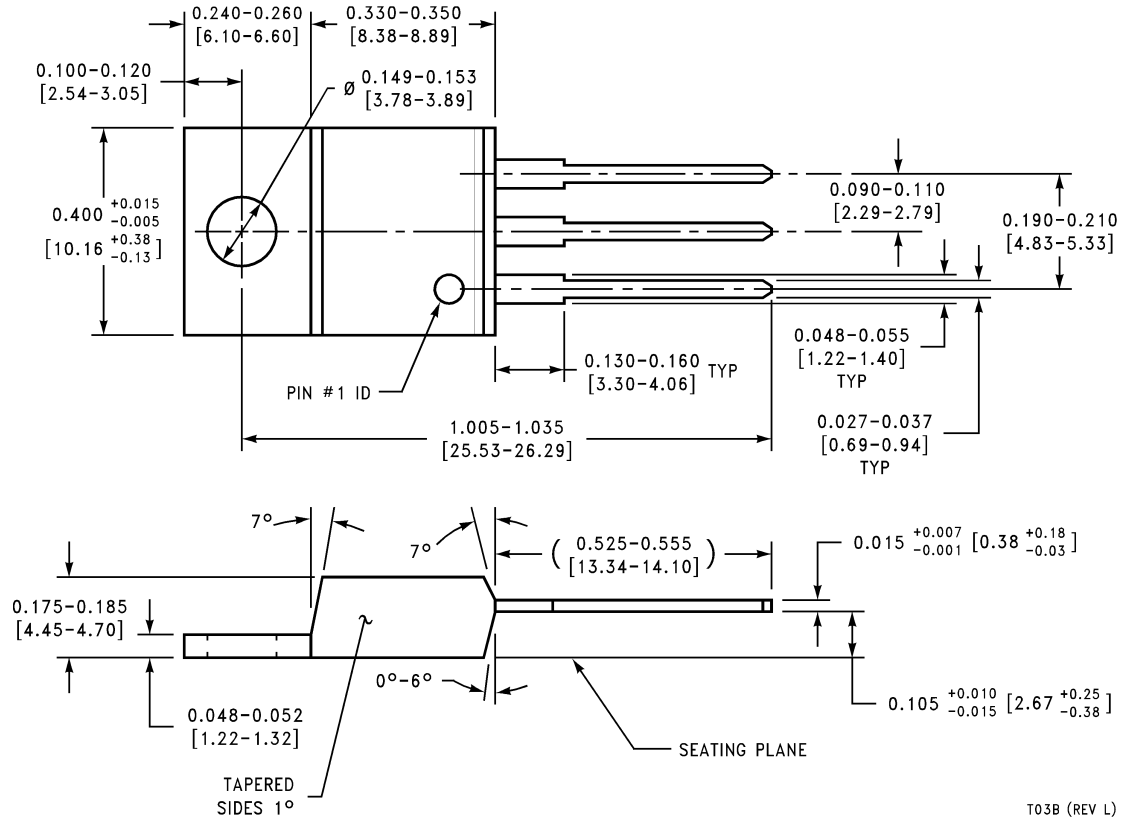

TO-220 Outline Package (T)
Order Number LM7905CT, LM7912CT or LM7915CT
NS Package Number T03B

National does not assume any responsibility for use of any circuitry described, no circuit patent licenses are implied and National reserves the right at any time without notice to change said circuitry and specifications.

For the most current product information visit us at www.national.com.

LIFE SUPPORT POLICY

NATIONAL'S PRODUCTS ARE NOT AUTHORIZED FOR USE AS CRITICAL COMPONENTS IN LIFE SUPPORT DEVICES OR SYSTEMS WITHOUT THE EXPRESS WRITTEN APPROVAL OF THE PRESIDENT AND GENERAL COUNSEL OF NATIONAL SEMICONDUCTOR CORPORATION. As used herein:

1. Life support devices or systems are devices or systems which, (a) are intended for surgical implant into the body, or (b) support or sustain life, and whose failure to perform when properly used in accordance with instructions for use provided in the labeling, can be reasonably expected to result in a significant injury to the user.
2. A critical component is any component of a life support device or system whose failure to perform can be reasonably expected to cause the failure of the life support device or system, or to affect its safety or effectiveness.

BANNED SUBSTANCE COMPLIANCE

National Semiconductor certifies that the products and packing materials meet the provisions of the Customer Products Stewardship Specification (CSP-9-111C2) and the Banned Substances and Materials of Interest Specification (CSP-9-111S2) and contain no "Banned Substances" as defined in CSP-9-111S2.

 **National Semiconductor**
Americas Customer Support Center
 Email: new.feedback@nsc.com
 Tel: 1-800-272-9959

National Semiconductor
Europe Customer Support Center
 Fax: +49 (0) 180-530 85 86
 Email: europa.support@nsc.com
 Deutsch Tel: +49 (0) 69 9508 6208
 English Tel: +44 (0) 870 24 0 2171
 Français Tel: +33 (0) 1 41 91 8790

National Semiconductor
Asia Pacific Customer Support Center
 Email: ap.support@nsc.com

National Semiconductor
Japan Customer Support Center
 Fax: 81-3-5639-7507
 Email: jpn.feedback@nsc.com
 Tel: 81-3-5639-7560

IMPORTANT NOTICE

Texas Instruments Incorporated and its subsidiaries (TI) reserve the right to make corrections, modifications, enhancements, improvements, and other changes to its products and services at any time and to discontinue any product or service without notice. Customers should obtain the latest relevant information before placing orders and should verify that such information is current and complete. All products are sold subject to TI's terms and conditions of sale supplied at the time of order acknowledgment.

TI warrants performance of its hardware products to the specifications applicable at the time of sale in accordance with TI's standard warranty. Testing and other quality control techniques are used to the extent TI deems necessary to support this warranty. Except where mandated by government requirements, testing of all parameters of each product is not necessarily performed.

TI assumes no liability for applications assistance or customer product design. Customers are responsible for their products and applications using TI components. To minimize the risks associated with customer products and applications, customers should provide adequate design and operating safeguards.

TI does not warrant or represent that any license, either express or implied, is granted under any TI patent right, copyright, mask work right, or other TI intellectual property right relating to any combination, machine, or process in which TI products or services are used. Information published by TI regarding third-party products or services does not constitute a license from TI to use such products or services or a warranty or endorsement thereof. Use of such information may require a license from a third party under the patents or other intellectual property of the third party, or a license from TI under the patents or other intellectual property of TI.

Reproduction of TI information in TI data books or data sheets is permissible only if reproduction is without alteration and is accompanied by all associated warranties, conditions, limitations, and notices. Reproduction of this information with alteration is an unfair and deceptive business practice. TI is not responsible or liable for such altered documentation. Information of third parties may be subject to additional restrictions.

Resale of TI products or services with statements different from or beyond the parameters stated by TI for that product or service voids all express and any implied warranties for the associated TI product or service and is an unfair and deceptive business practice. TI is not responsible or liable for any such statements.

TI products are not authorized for use in safety-critical applications (such as life support) where a failure of the TI product would reasonably be expected to cause severe personal injury or death, unless officers of the parties have executed an agreement specifically governing such use. Buyers represent that they have all necessary expertise in the safety and regulatory ramifications of their applications, and acknowledge and agree that they are solely responsible for all legal, regulatory and safety-related requirements concerning their products and any use of TI products in such safety-critical applications, notwithstanding any applications-related information or support that may be provided by TI. Further, Buyers must fully indemnify TI and its representatives against any damages arising out of the use of TI products in such safety-critical applications.

TI products are neither designed nor intended for use in military/aerospace applications or environments unless the TI products are specifically designated by TI as military-grade or "enhanced plastic." Only products designated by TI as military-grade meet military specifications. Buyers acknowledge and agree that any such use of TI products which TI has not designated as military-grade is solely at the Buyer's risk, and that they are solely responsible for compliance with all legal and regulatory requirements in connection with such use.

TI products are neither designed nor intended for use in automotive applications or environments unless the specific TI products are designated by TI as compliant with ISO/TS 16949 requirements. Buyers acknowledge and agree that, if they use any non-designated products in automotive applications, TI will not be responsible for any failure to meet such requirements.

Following are URLs where you can obtain information on other Texas Instruments products and application solutions:

Products

Audio	www.ti.com/audio
Amplifiers	amplifier.ti.com
Data Converters	dataconverter.ti.com
DLP® Products	www.dlp.com
DSP	dsp.ti.com
Clocks and Timers	www.ti.com/clocks
Interface	interface.ti.com
Logic	logic.ti.com
Power Mgmt	power.ti.com
Microcontrollers	microcontroller.ti.com
RFID	www.ti-rfid.com
OMAP Mobile Processors	www.ti.com/omap
Wireless Connectivity	www.ti.com/wirelessconnectivity

Applications

Communications and Telecom	www.ti.com/communications
Computers and Peripherals	www.ti.com/computers
Consumer Electronics	www.ti.com/consumer-apps
Energy and Lighting	www.ti.com/energy
Industrial	www.ti.com/industrial
Medical	www.ti.com/medical
Security	www.ti.com/security
Space, Avionics and Defense	www.ti.com/space-avionics-defense
Transportation and Automotive	www.ti.com/automotive
Video and Imaging	www.ti.com/video

TI E2E Community Home Page

e2e.ti.com

Mailing Address: Texas Instruments, Post Office Box 655303, Dallas, Texas 75265
Copyright © 2011, Texas Instruments Incorporated