

DMOS FULL BRIDGE DRIVER

- SUPPLY VOLTAGE UP TO 48V
- 5A MAX PEAK CURRENT (2A max. for L6201)
- TOTAL RMS CURRENT UP TO
L6201: 1A; L6202: 1.5A; L6203/L6201PS: 4A
- $R_{DS(ON)}$ 0.3 Ω (typical value at 25 °C)
- CROSS CONDUCTION PROTECTION
- TTL COMPATIBLE DRIVE
- OPERATING FREQUENCY UP TO 100 KHz
- THERMAL SHUTDOWN
- INTERNAL LOGIC SUPPLY
- HIGH EFFICIENCY

DESCRIPTION

The I.C. is a full bridge driver for motor control applications realized in Multipower-BCD technology which combines isolated DMOS power transistors with CMOS and Bipolar circuits on the same chip. By using mixed technology it has been possible to optimize the logic circuitry and the power stage to achieve the best possible performance. The DMOS output transistors can operate at supply voltages up to 42V and efficiently at high switch-

MULTIPOWER BCD TECHNOLOGY

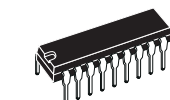

Powerdip 12+3+3

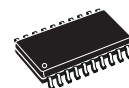

SO20 (12+4+4)

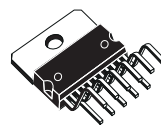

Multiwatt11



PowerSO20

ORDERING NUMBERS:

L6201 (SO20)
L6201PS (PowerSO20)
L6202 (Powerdip18)
L6203 (Multiwatt)

ing speeds. All the logic inputs are TTL, CMOS and μ C compatible. Each channel (half-bridge) of the device is controlled by a separate logic input, while a common enable controls both channels. The I.C. is mounted in three different packages.

BLOCK DIAGRAM

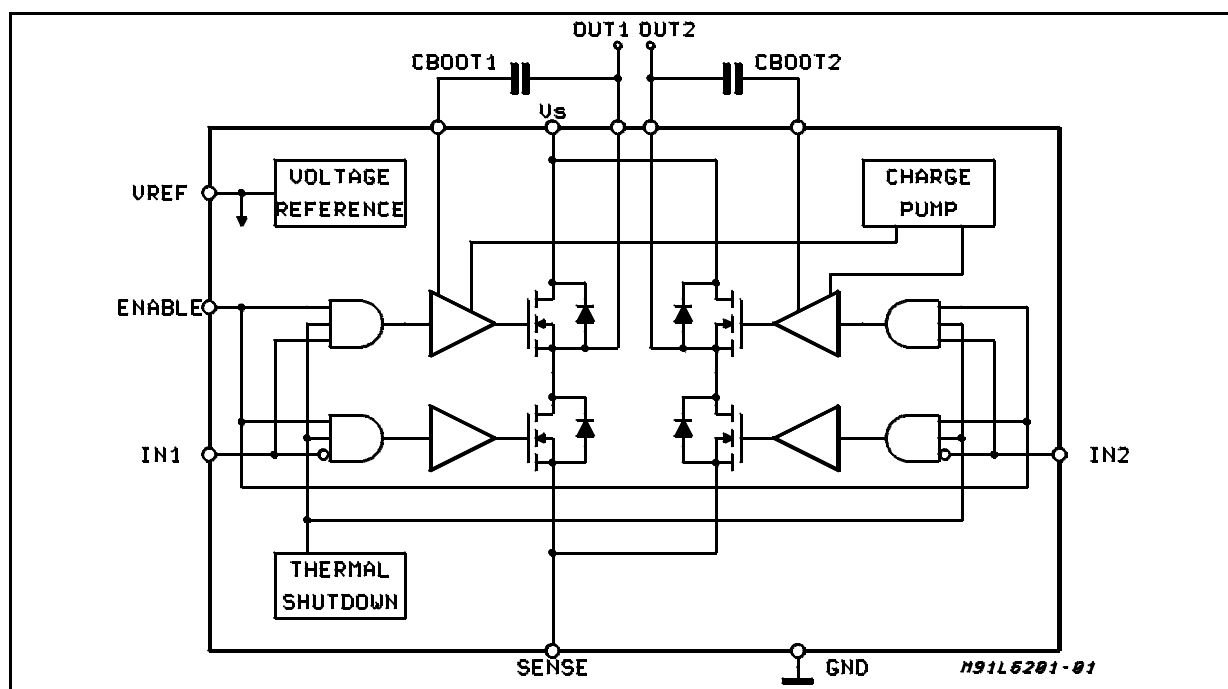

PIN CONNECTIONS (Top view)

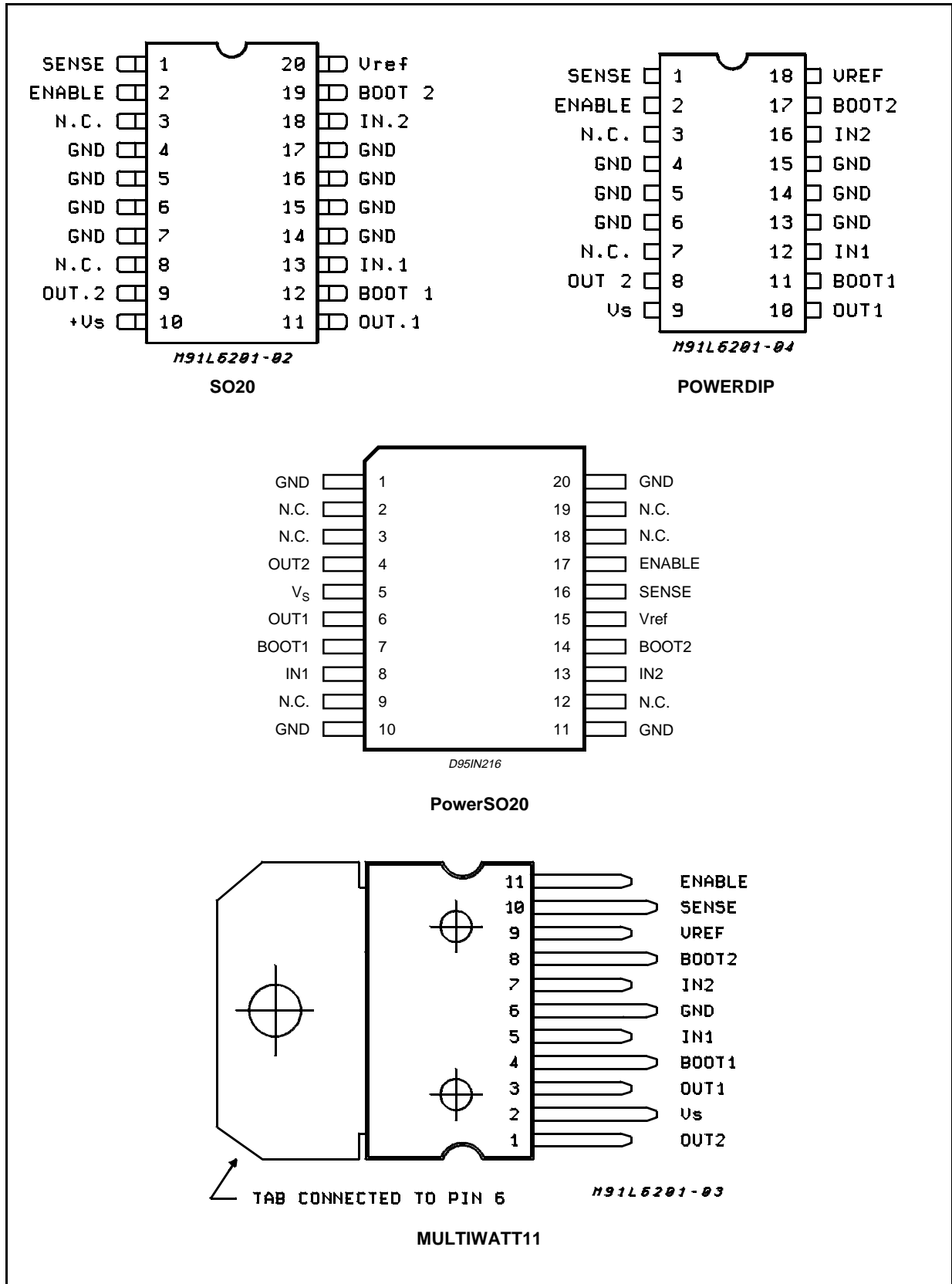

PINS FUNCTIONS

Device				Name	Function
L6201	L6201PS	L6202	L6203		
1	16	1	10	SENSE	A resistor R_{sense} connected to this pin provides feedback for motor current control.
2	17	2	11	ENABLE	When a logic high is present on this pin the DMOS POWER transistors are enabled to be selectively driven by IN1 and IN2.
3	2,3,9,12,18,19	3		N.C.	Not Connected
4,5	–	4	6	GND	Common Ground Terminal
–	1, 10	5		GND	Common Ground Terminal
6,7	–	6		GND	Common Ground Terminal
8	–	7		N.C.	Not Connected
9	4	8	1	OUT2	Output of 2nd Half Bridge
10	5	9	2	V_s	Supply Voltage
11	6	10	3	OUT1	Output of first Half Bridge
12	7	11	4	BOOT1	A bootstrap capacitor connected to this pin ensures efficient driving of the upper POWER DMOS transistor.
13	8	12	5	IN1	Digital Input from the Motor Controller
14,15	–	13	6	GND	Common Ground Terminal
–	11, 20	14		GND	Common Ground Terminal
16,17	–	15		GND	Common Ground Terminal
18	13	16	7	IN2	Digital Input from the Motor Controller
19	14	17	8	BOOT2	A bootstrap capacitor connected to this pin ensures efficient driving of the upper POWER DMOS transistor.
20	15	18	9	V_{ref}	Internal voltage reference. A capacitor from this pin to GND is recommended. The internal Ref. Voltage can source out a current of 2mA max.

ABSOLUTE MAXIMUM RATINGS

Symbol	Parameter	Value	Unit
V_s	Power Supply	52	V
V_{OD}	Differential Output Voltage (between Out1 and Out2)	60	V
V_{IN}, V_{EN}	Input or Enable Voltage	– 0.3 to + 7	V
I_o	Pulsed Output Current for L6201PS/L6202/L6203 (Note 1)	5	A
	– Non Repetitive (< 1 ms) for L6201	5	A
	DC Output Current for L6201PS/L6202/L6203 for L6201 (Note 1)	10 1	A A
V_{sense}	Sensing Voltage	– 1 to + 4	V
V_b	Bootstrap Peak Voltage	60	V
P_{tot}	Total Power Dissipation:		
	$T_{pins} = 90^\circ\text{C}$ for L6201	4	W
	for L6202	5	W
	$T_{case} = 90^\circ\text{C}$ for L6201PS/L6203	20	W
	$T_{amb} = 70^\circ\text{C}$ for L6201 (Note 2)	0.9	W
for L6202 (Note 2)	1.3	W	
for L6201PS/L6203 (Note 2)	2.3	W	
T_{stg}, T_j	Storage and Junction Temperature	– 40 to + 150	$^\circ\text{C}$

Note 1: Pulse width limited only by junction temperature and transient thermal impedance (see thermal characteristics)

Note 2: Mounted on board with minimized dissipating copper area.

L6201 - L6202 - L6203

THERMAL DATA

Symbol	Parameter		Value				Unit
			L6201	L6201PS	L6202	L6203	
R _{th j-pins}	Thermal Resistance Junction-pins	max	15	–	12	–	°C/W
R _{th j-case}	Thermal Resistance Junction Case	max.	–	–	–	3	
R _{th j-amb}	Thermal Resistance Junction-ambient	max.	85	13 (*)	60	35	

(*) Mounted on aluminium substrate.

ELECTRICAL CHARACTERISTICS (Refer to the Test Circuits; T_j = 25°C, V_s = 42V, V_{sens} = 0, unless otherwise specified).

Symbol	Parameter	Test Conditions	Min.	Typ.	Max.	Unit
V _s	Supply Voltage		12	36	48	V
V _{ref}	Reference Voltage	I _{REF} = 2mA		13.5		V
I _{REF}	Output Current				2	mA
I _s	Quiescent Supply Current	EN = H V _{IN} = L EN = H V _{IN} = H EN = L (Fig. 1,2,3) I _L = 0		10 10 8	15 15 15	mA mA mA
f _c	Commutation Frequency (*)			30	100	KHz
T _j	Thermal Shutdown			150		°C
T _d	Dead Time Protection			100		ns

TRANSISTORS

OFF						
I _{DSS}	Leakage Current	Fig. 11 V _s = 52 V			1	mA
ON						
R _{DS}	On Resistance	Fig. 4,5		0.3	0.55	Ω
V _{DS(ON)}	Drain Source Voltage	Fig. 9 I _{DS} = 1A I _{DS} = 1.2A I _{DS} = 3A	L6201 L6202 L6201PS/0 3	0.3 0.36 0.9		V V V
V _{sens}	Sensing Voltage			– 1	4	V

SOURCE DRAIN DIODE

V _{sd}	Forward ON Voltage	Fig. 6a and b I _{SD} = 1A L6201 EN = L I _{SD} = 1.2A L6202 EN = L I _{SD} = 3A L6201PS/03 EN = L		0.9 (**) 0.9 (**) 1.35 (**)		V V V
t _{rr}	Reverse Recovery Time	$\frac{di_f}{dt} = 25 \text{ A}/\mu\text{s}$ I _F = 1A L6201 I _F = 1.2A L6202 I _F = 3A L6203		300		ns
t _{fr}	Forward Recovery Time			200		ns

LOGIC LEVELS

V _{IN L} , V _{EN L}	Input Low Voltage		– 0.3		0.8	V
V _{IN H} , V _{EN H}	Input High Voltage		2		7	V
I _{IN L} , I _{EN L}	Input Low Current	V _{IN} , V _{EN} = L			–10	μA
I _{IN H} , I _{EN H}	Input High Current	V _{IN} , V _{EN} = H		30		μA

ELECTRICAL CHARACTERISTICS (Continued)
LOGIC CONTROL TO POWER DRIVE TIMING

Symbol	Parameter	Test Conditions	Min.	Typ.	Max.	Unit
t ₁ (V _i)	Source Current Turn-off Delay	Fig. 12		300		ns
t ₂ (V _i)	Source Current Fall Time	Fig. 12		200		ns
t ₃ (V _i)	Source Current Turn-on Delay	Fig. 12		400		ns
t ₄ (V _i)	Source Current Rise Time	Fig. 12		200		ns
t ₅ (V _i)	Sink Current Turn-off Delay	Fig. 13		300		ns
t ₆ (V _i)	Sink Current Fall Time	Fig. 13		200		ns
t ₇ (V _i)	Sink Current Turn-on Delay	Fig. 13		400		ns
t ₈ (V _i)	Sink Current Rise Time	Fig. 13		200		ns

(*) Limited by power dissipation

(**) In synchronous rectification the drain-source voltage drop V_{DS} is shown in fig. 4 (L6202/03); typical value for the L6201 is of 0.3V.

Figure 1: Typical Normalized I_S vs. T_J

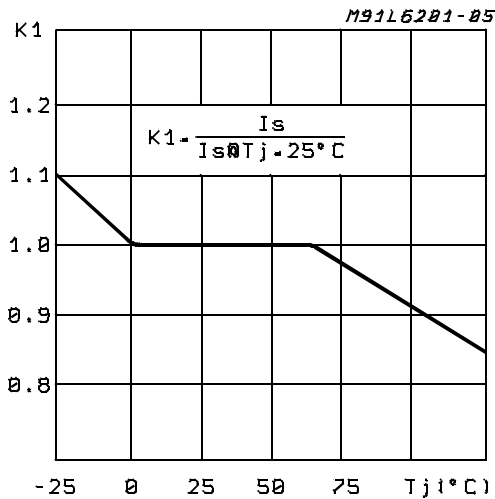

Figure 2: Typical Normalized Quiescent Current vs. Frequency

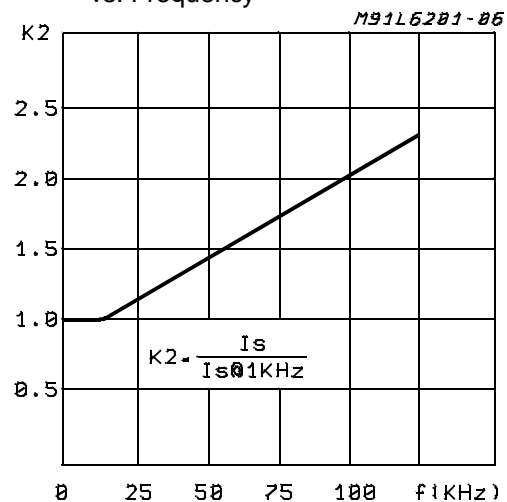

Figure 3: Typical Normalized I_S vs. V_S

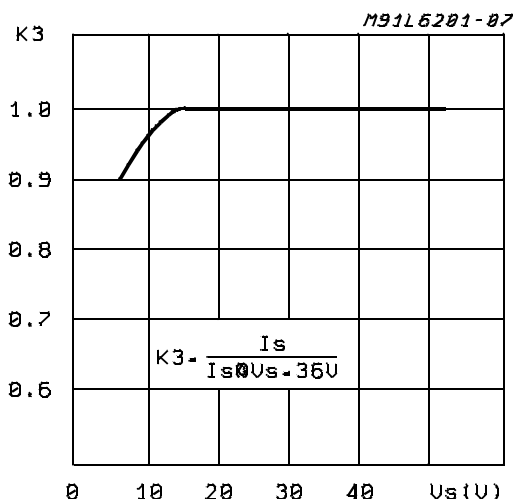

Figure 4: Typical R_{DS(ON)} vs. V_S ~ V_{ref}

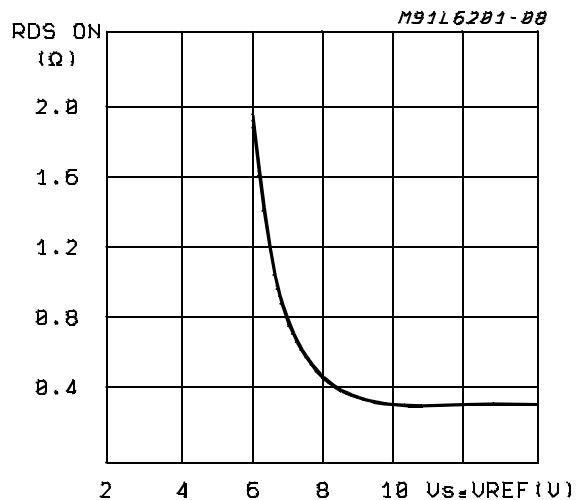

Figure 5: Normalized $R_{DS(ON)}$ at 25°C vs. Temperature Typical Values

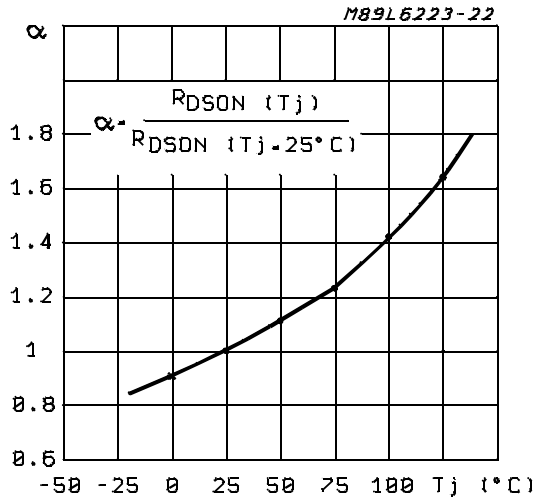

Figure 6a: Typical Diode Behaviour in Synchronous Rectification (L6201)

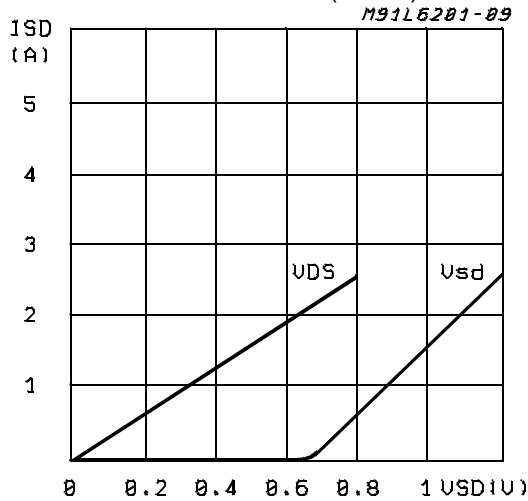

Figure 6b: Typical Diode Behaviour in Synchronous Rectification (L6201PS/02/03)

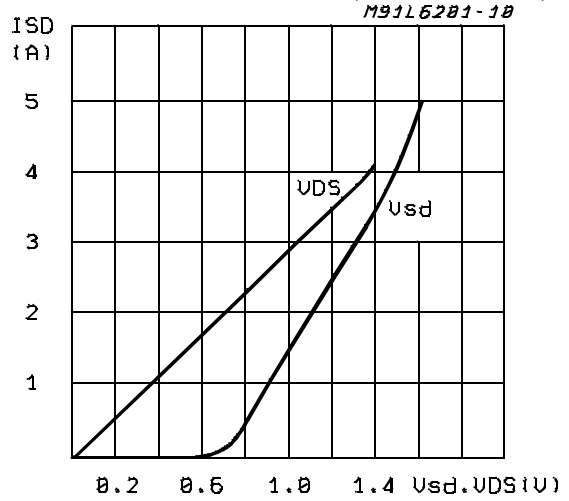

Figure 7a: Typical Power Dissipation vs I_L (L6201)

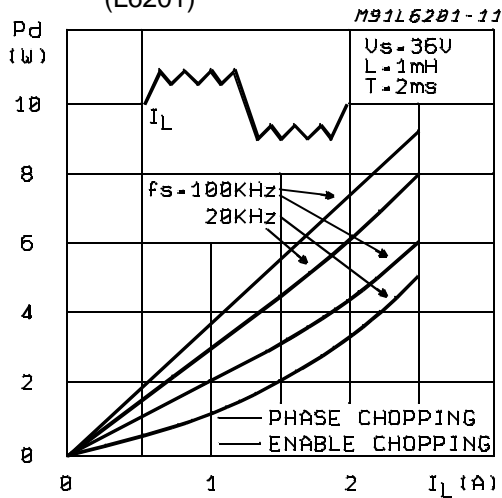
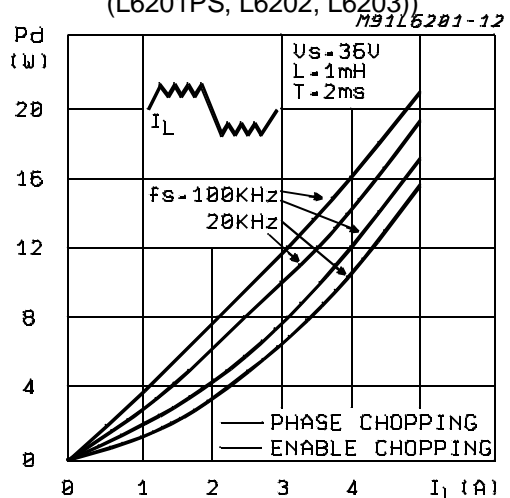
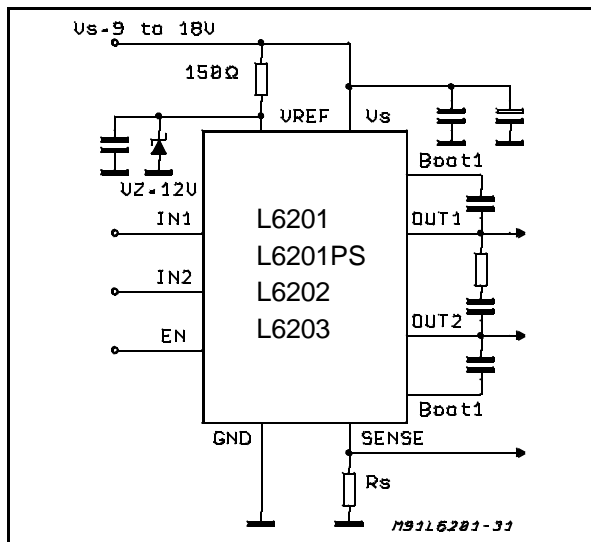

Figure 7b: Typical Power Dissipation vs I_L (L6201PS, L6202, L6203)



It could be requested to drive a motor at V_s lower than the minimum recommended one of 12V (See Electrical Characteristics); in this case, by accepting a possible small increase in the $R_{DS(ON)}$ resistance of the power output transistors at the lowest Supply Voltage value, may be a good solution the one shown in Fig. 20.

Figure 20: L6201/1P/2/3 Used at a Supply Voltage Range Between 9 and 18V



THERMAL CHARACTERISTICS

Thanks to the high efficiency of this device, often a true heatsink is not needed or it is simply obtained by means of a copper side on the P.C.B. (L6201/2).

Under heavy conditions, the L6203 needs a suitable cooling.

By using two square copper sides in a similar way as it shown in Fig. 23, Fig. 21 indicates how to choose the on board heatsink area when the L6201 total power dissipation is known since:

$$R_{Th\ j-amb} = (T_{j\ max.} - T_{amb\ max}) / P_{tot}$$

Figure 22 shows the Transient Thermal Resistance vs. a single pulse time width.

Figure 23 and 24 refer to the L6202.

For the Multiwatt L6203 additional information is given by Figure 25 (Thermal Resistance Junction-Ambient vs. Total Power Dissipation) and Figure 26 (Peak Transient Thermal Resistance vs. Repetitive Pulse Width) while Figure 27 refers to the single pulse Transient Thermal Resistance.

Figure 21: Typical $R_{Th\ J-amb}$ vs. "On Board" Heatsink Area (L6201)

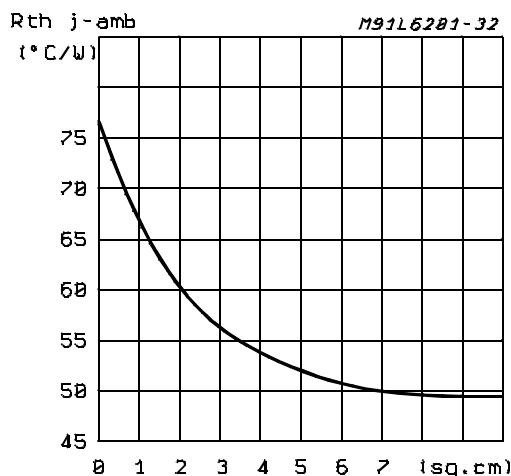

Figure 22: Typical Transient R_{Th} in Single Pulse Condition (L6201)

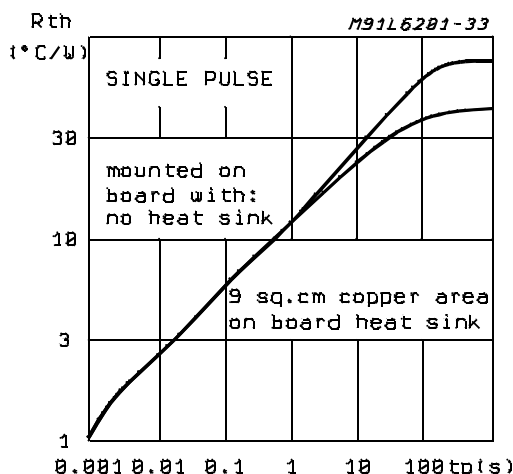

Figure 23: Typical $R_{Th\ J-amb}$ vs. Two "On Board" Square Heatsink (L6202)

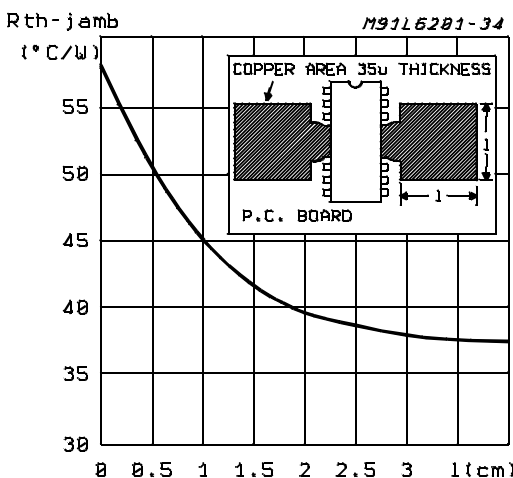

Figure 24: Typical Transient Thermal Resistance for Single Pulses (L6202)

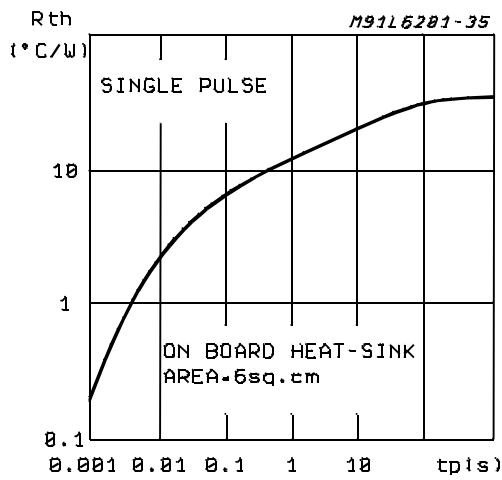

Figure 25: Typical $R_{Th J-amb}$ of Multiwatt Package vs. Total Power Dissipation

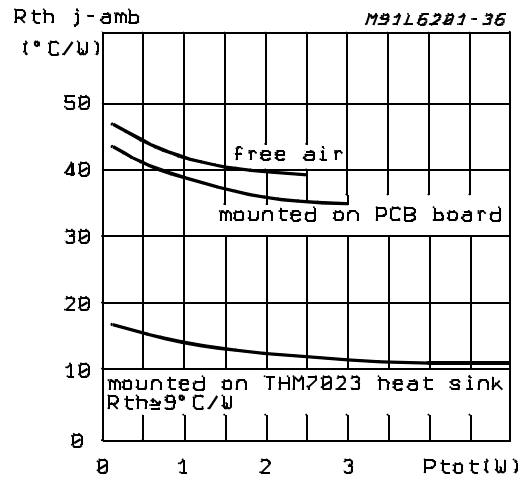

Figure 26: Typical Transient Thermal Resistance for Single Pulses with and without Heatsink (L6203)

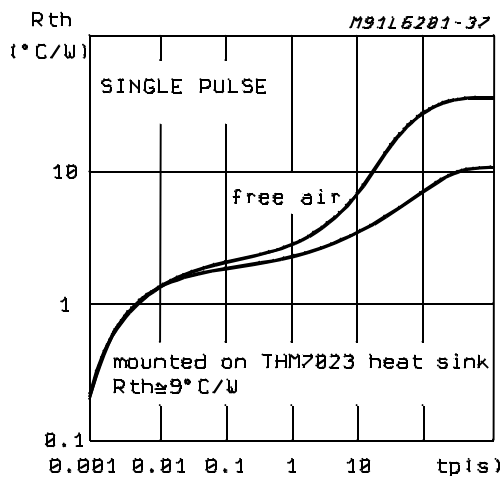
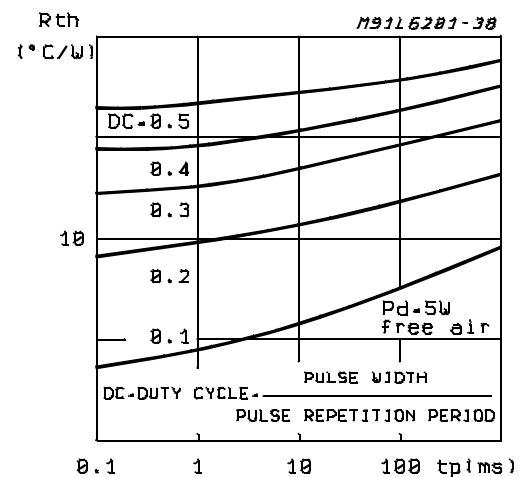
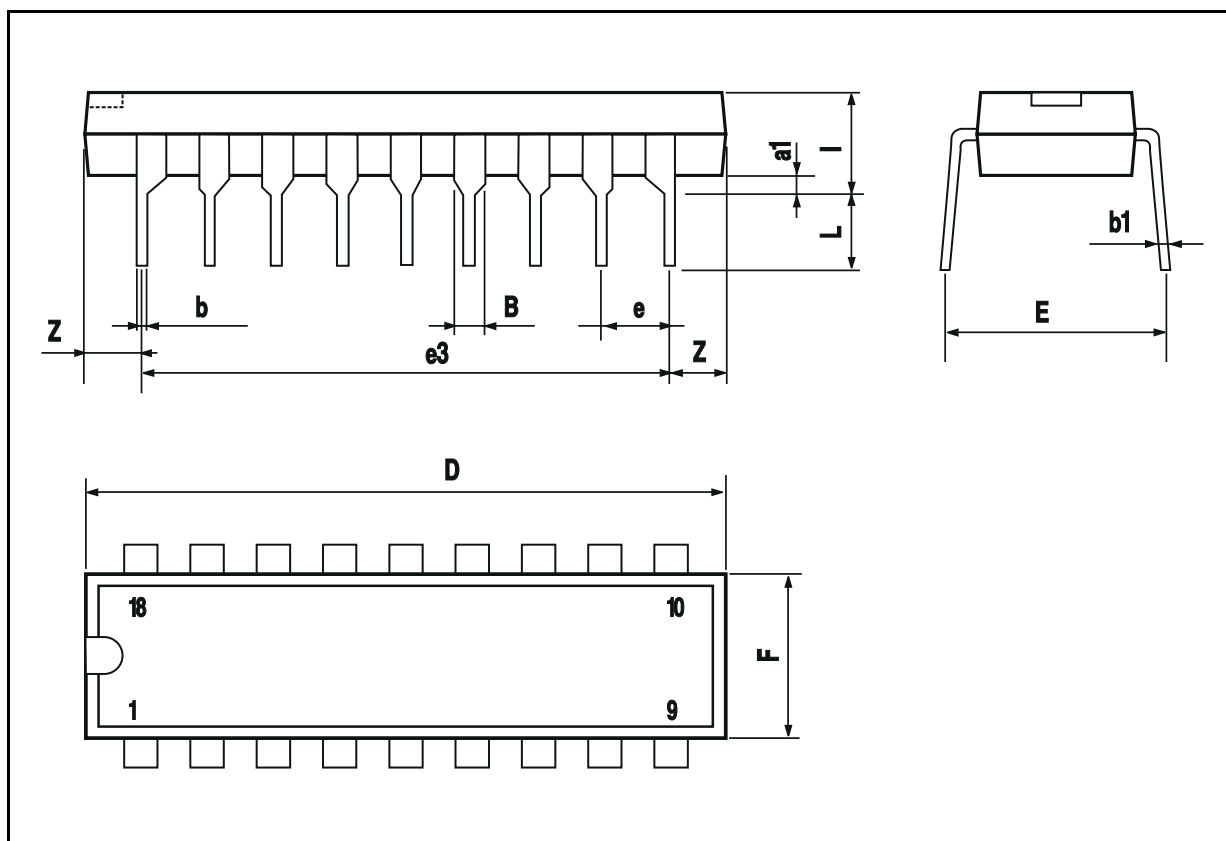

Figure 27: Typical Transient Thermal Resistance versus Pulse Width and Duty Cycle (L6203)



POWERDIP18 PACKAGE MECHANICAL DATA

DIM.	mm			inch		
	MIN.	TYP.	MAX.	MIN.	TYP.	MAX.
a1	0.51			0.020		
B	0.85		1.40	0.033		0.055
b		0.50			0.020	
b1	0.38		0.50	0.015		0.020
D			24.80			0.976
E		8.80			0.346	
e		2.54			0.100	
e3		20.32			0.800	
F			7.10			0.280
l			5.10			0.201
L		3.30			0.130	
Z			2.54			0.100



SO20 PACKAGE MECHANICAL DATA

DIM.	mm			inch		
	MIN.	TYP.	MAX.	MIN.	TYP.	MAX.
A			2.65			0.104
a1	0.1		0.3	0.004		0.012
a2			2.45			0.096
b	0.35		0.49	0.014		0.019
b1	0.23		0.32	0.009		0.013
C		0.5			0.020	
c1	45 (typ.)					
D	12.6		13.0	0.496		0.512
E	10		10.65	0.394		0.419
e		1.27			0.050	
e3		11.43			0.450	
F	7.4		7.6	0.291		0.299
L	0.5		1.27	0.020		0.050
M			0.75			0.030
S	8 (max.)					

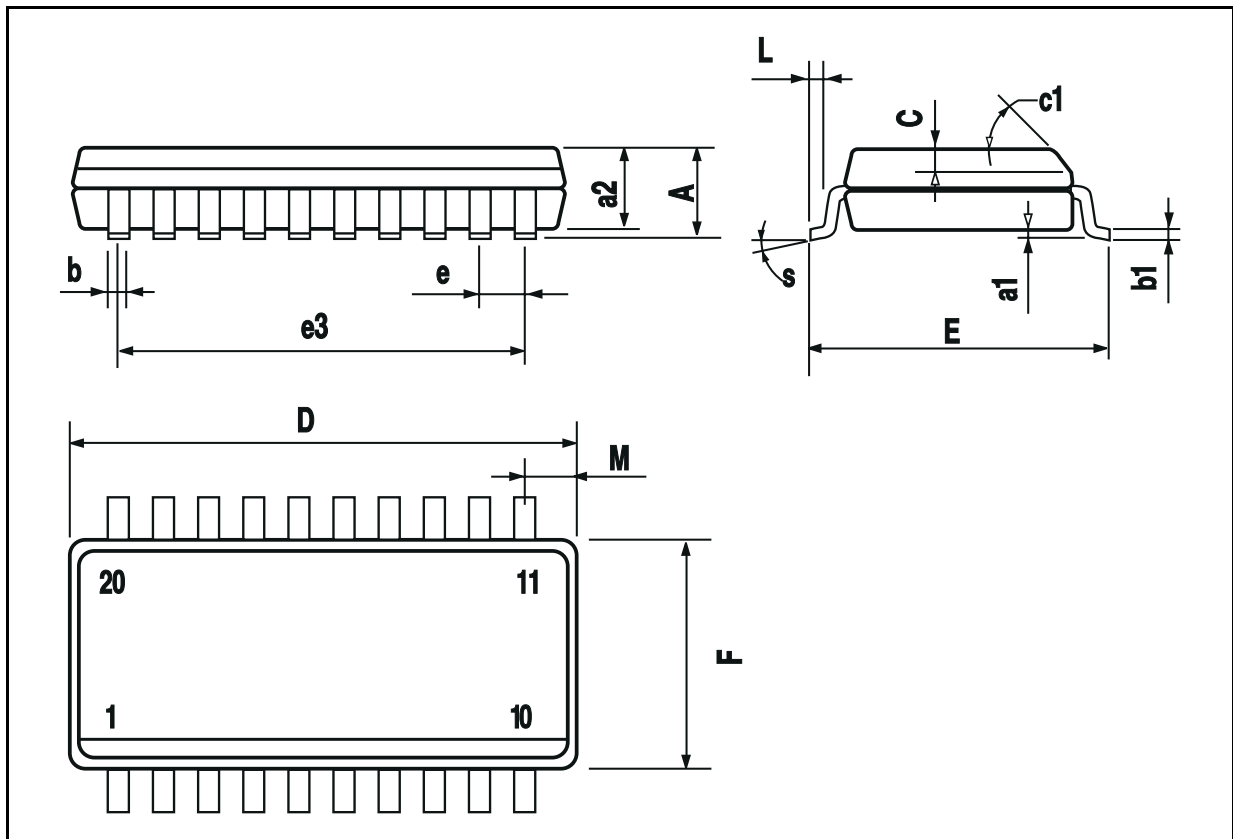

PowerSO20 PACKAGE MECHANICAL DATA

DIM.	mm			inch		
	MIN.	TYP.	MAX.	MIN.	TYP.	MAX.
A			3.60			0.1417
a1	0.10		0.30	0.0039		0.0118
a2			3.30			0.1299
a3	0		0.10	0		0.0039
b	0.40		0.53	0.0157		0.0209
c	0.23		0.32	0.009		0.0126
D (1)	15.80		16.00	0.6220		0.6299
E	13.90		14.50	0.5472		0.570
e		1.27			0.050	
e3		11.43			0.450	
E1 (1)	10.90		11.10	0.4291		0.437
E2			2.90			0.1141
G	0		0.10	0		0.0039
h			1.10			
L	0.80		1.10	0.0314		0.0433
N	10° (max.)					
S	8° (max.)					
T		10.0			0.3937	

(1) "D and E1" do not include mold flash or protrusions
 - Mold flash or protrusions shall not exceed 0.15mm (0.006")

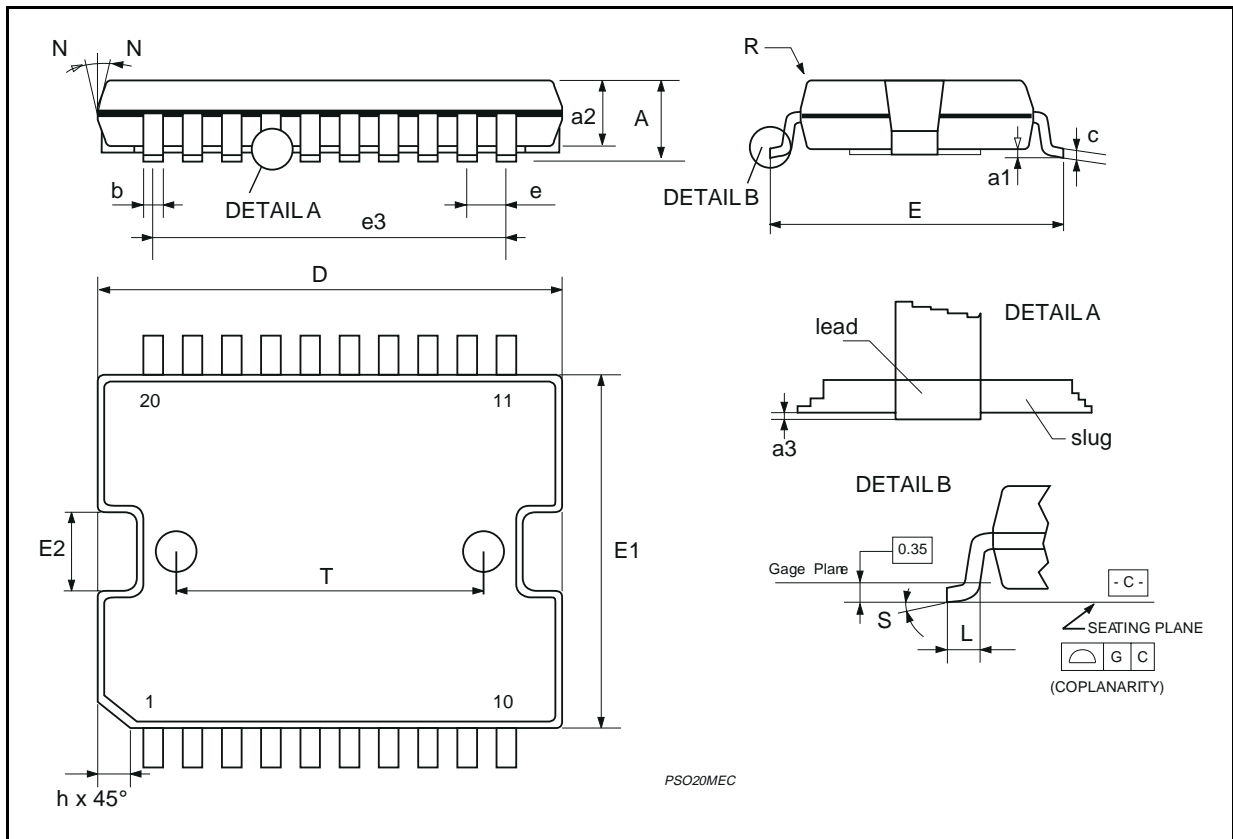

MULTIWATT11 PACKAGE MECHANICAL DATA

DIM.	mm			inch		
	MIN.	TYP.	MAX.	MIN.	TYP.	MAX.
A			5			0.197
B			2.65			0.104
C			1.6			0.063
D		1			0.039	
E	0.49		0.55	0.019		0.022
F	0.88		0.95	0.035		0.037
G	1.57	1.7	1.83	0.062	0.067	0.072
G1	16.87	17	17.13	0.664	0.669	0.674
H1	19.6			0.772		
H2			20.2			0.795
L	21.5		22.3	0.846		0.878
L1	21.4		22.2	0.843		0.874
L2	17.4		18.1	0.685		0.713
L3	17.25	17.5	17.75	0.679	0.689	0.699
L4	10.3	10.7	10.9	0.406	0.421	0.429
L7	2.65		2.9	0.104		0.114
M	4.1	4.3	4.5	0.161	0.169	0.177
M1	4.88	5.08	5.3	0.192	0.200	0.209
S	1.9		2.6	0.075		0.102
S1	1.9		2.6	0.075		0.102
Dia1	3.65		3.85	0.144		0.152

