

# LM389 Low Voltage Audio Power Amplifier with NPN Transistor Array

## General Description

The LM389 is an array of three NPN transistors on the same substrate with an audio power amplifier similar to the LM386.

The amplifier inputs are ground referenced while the output is automatically biased to one half the supply voltage. The gain is internally set at 20 to minimize external parts, but the addition of an external resistor and capacitor between pins 4 and 12 will increase the gain to any value up to 200.

The three transistors have high gain and excellent matching characteristics. They are well suited to a wide variety of applications in DC through VHF systems.

## Features

### Amplifier

- Battery operation
- Minimum external parts
- Wide supply voltage range

- Low quiescent current drain
- Voltage gains from 20 to 200
- Ground referenced input
- Self-centering output quiescent voltage
- Low distortion

### Transistors

- Operation from 1  $\mu$ A to 25 mA
- Frequency range from DC to 100 MHz
- Excellent matching

## Applications

- AM-FM radios
- Portable tape recorders
- Intercoms
- Toys and games
- Walkie-talkies
- Portable phonographs
- Power converters

## Equivalent Schematic and Connection Diagrams

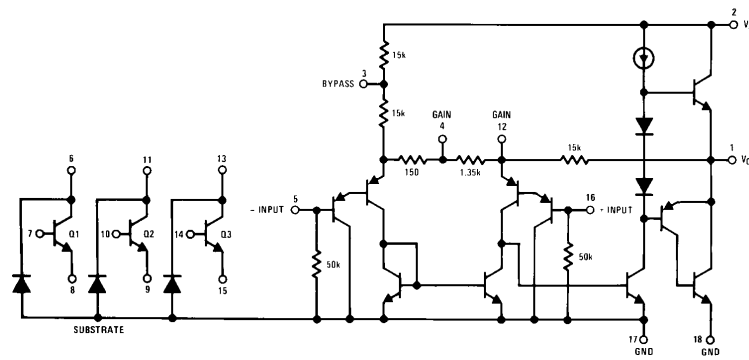

TL/H/7847-1

### Dual-In-Line Package

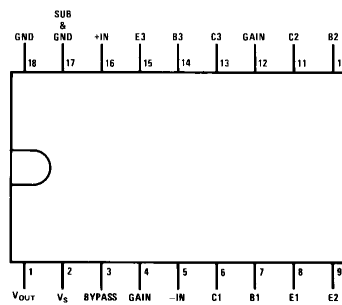

TL/H/7847-2

**Order Number LM389N**  
See NS Package Number N18A

LM389 Low Voltage Audio Power Amplifier with NPN Transistor Array

## Absolute Maximum Ratings

If Military/Aerospace specified devices are required, please contact the National Semiconductor Sales Office/Distributors for availability and specifications.

Supply Voltage	15V	Collector to Base Voltage, $V_{CBO}$	15V
Package Dissipation (Note 1)	1.89W	Collector to Substrate Voltage, $V_{CIO}$ (Note 2)	15V
Input Voltage	$\pm 0.4V$	Collector Current, $I_C$	25 mA
Storage Temperature	$-65^\circ\text{C}$ to $+150^\circ\text{C}$	Emitter Current, $I_E$	25 mA
Operating Temperature	$0^\circ\text{C}$ to $+70^\circ\text{C}$	Base Current, $I_B$	5 mA
Junction Temperature	$150^\circ\text{C}$	Power Dissipation (Each Transistor) $T_A \leq +70^\circ\text{C}$	150 mW
Lead Temperature (Soldering, 10 sec.)	$260^\circ\text{C}$	Thermal Resistance	
Collector to Emitter Voltage, $V_{CEO}$	12V	$\theta_{JC}$	$24^\circ\text{C}/\text{W}$
		$\theta_{JA}$	$70^\circ\text{C}/\text{W}$

## Electrical Characteristics $T_A = 25^\circ\text{C}$

Symbol	Parameter	Conditions	Min	Typ	Max	Units
<b>AMPLIFIER</b>						
$V_S$	Operating Supply Voltage		4		12	V
$I_Q$	Quiescent Current	$V_S = 6V, V_{IN} = 0V$		6	12	mA
$P_{OUT}$	Output Power (Note 3)	THD = 10% $V_S = 6V, R_L = 8\Omega$ $V_S = 9V, R_L = 16\Omega$	250	325 500		mW mW
$A_V$	Voltage Gain	$V_S = 6V, f = 1\text{ kHz}$ $10\ \mu\text{F}$ from Pins 4 to 12	23	26 46	30	dB dB
BW	Bandwidth	$V_S = 6V$ , Pins 4 and 12 Open		250		kHz
THD	Total Harmonic Distortion	$V_S = 6V, R_L = 8\Omega, P_{OUT} = 125\text{ mW}$ , $f = 1\text{ kHz}$ , Pins 4 and 12 Open		0.2	3.0	%
PSRR	Power Supply Rejection Ratio	$V_S = 6V, f = 1\text{ kHz}, C_{BYPASS} = 10\ \mu\text{F}$ , Pins 4 and 12 Open, Referred to Output	30	50		dB
$R_{IN}$	Input Resistance		10	50		k $\Omega$
$I_{BIAS}$	Input Bias Current	$V_S = 6V$ , Pins 5 and 16 Open		250		nA
<b>TRANSISTORS</b>						
$V_{CEO}$	Collector to Emitter Breakdown Voltage	$I_C = 1\text{ mA}, I_B = 0$	12	20		V
$V_{CBO}$	Collector to Base Breakdown Voltage	$I_C = 10\ \mu\text{A}, I_E = 0$	15	40		V
$V_{CIO}$	Collector to Substrate Breakdown Voltage	$I_C = 10\ \mu\text{A}, I_E = I_B = 0$	15	40		V
$V_{EBO}$	Emitter to Base Breakdown Voltage	$I_E = 10\ \mu\text{A}, I_C = 0$	6.4	7.1	7.8	V
$h_{FE}$	Static Forward Current Transfer Ratio (Static Beta)	$I_C = 10\ \mu\text{A}$ $I_C = 1\text{ mA}$ $I_C = 10\text{ mA}$	100	100 275 275		
$h_{oe}$	Open-Circuit Output Admittance	$I_C = 1\text{ mA}, V_{CE} = 5V, f = 1.0\text{ kHz}$		20		$\mu\text{mho}$
$V_{BE}$	Base to Emitter Voltage	$I_E = 1\text{ mA}$		0.7	0.85	V
$ V_{BE1} - V_{BE2} $	Base to Emitter Voltage Offset	$I_E = 1\text{ mA}$		1	5	mV
$V_{CESAT}$	Collector to Emitter Saturation Voltage	$I_C = 10\text{ mA}, I_B = 1\text{ mA}$		0.15	0.5	V
$C_{EB}$	Emitter to Base Capacitance	$V_{EB} = 3V$		1.5		pF
$C_{CB}$	Collector to Base Capacitance	$V_{CB} = 3V$		2		pF
$C_{CI}$	Collector to Substrate Capacitance	$V_{CI} = 3V$		3.5		pF
$h_{fe}$	High Frequency Current Gain	$I_C = 10\text{ mA}, V_{CE} = 5V, f = 100\text{ MHz}$	1.5	5.5		

**Note 1:** For operation in ambient temperatures above  $25^\circ\text{C}$ , the device must be derated based on a  $150^\circ\text{C}$  maximum junction temperature and a thermal resistance of  $66^\circ\text{C}/\text{W}$  junction to ambient.

**Note 2:** The collector of each transistor is isolated from the substrate by an integral diode. Therefore, the collector voltage should remain positive with respect to pin 17 at all times.

**Note 3:** If oscillation exists under some load conditions, add  $2.7\Omega$  and  $0.05\ \mu\text{F}$  series network from pin 1 to ground.

# Typical Amplifier Performance Characteristics

**Quiescent Supply Current vs Supply Voltage**

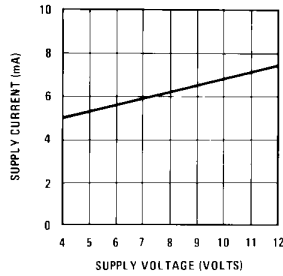

**Power Supply Rejection Ratio (Referred to the Output) vs Frequency**

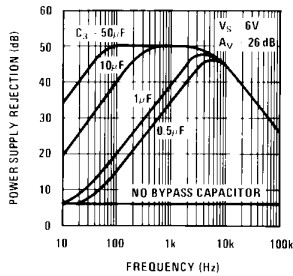

**Peak-to-Peak Output Voltage Swing vs Supply Voltage**

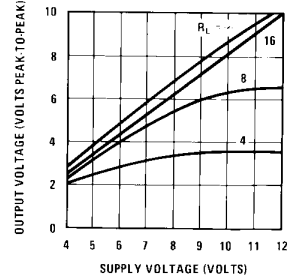

**Voltage Gain vs Frequency**

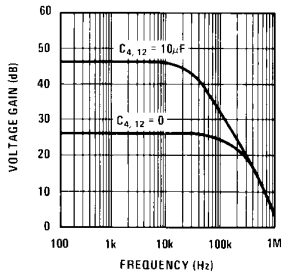

**Distortion vs Frequency**

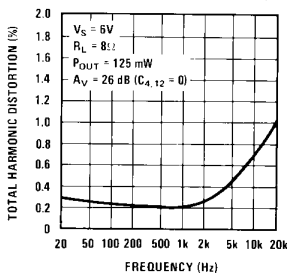

**Distortion vs Output Power**

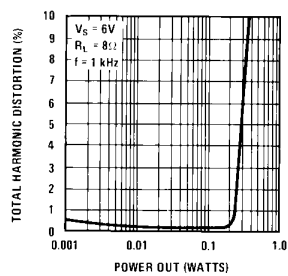

**Device Dissipation vs Output Power—4Ω Load**

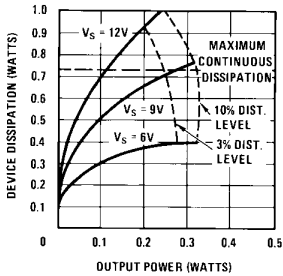

**Device Dissipation vs Output Power—8Ω Load**

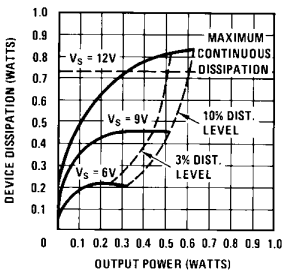

**Device Dissipation vs Output Power—16Ω Load**

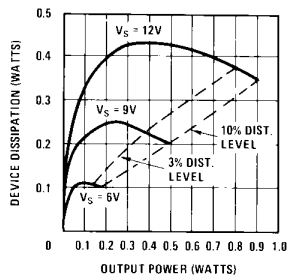

TL/H/7847-3

# Typical Transistor Performance Characteristics

**Forward Current Transfer Ratio vs Collector Current**

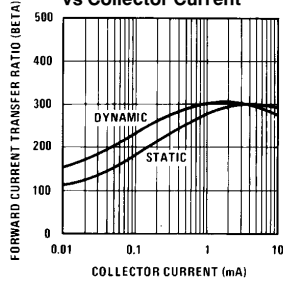

**Saturation Voltage vs Collector Current**

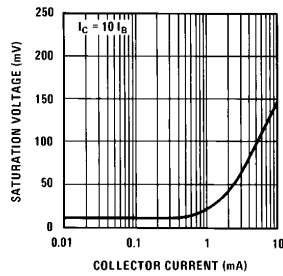

**Open Circuit Output Admittance vs Collector Current**

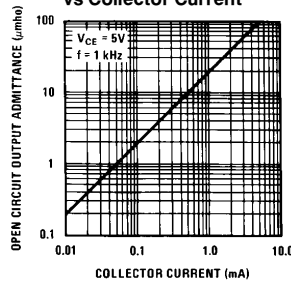

TL/H/7847-4

**Noise Voltage vs Frequency**

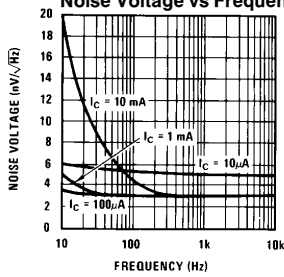

**Noise Current vs Frequency**

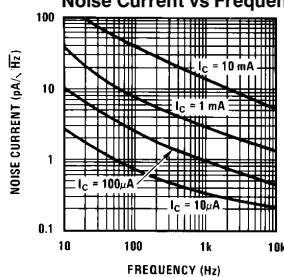

**High Frequency Current Gain vs Collector Current**

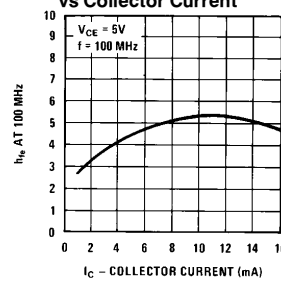

**g<sub>oe</sub> and C<sub>oe</sub> vs Collector Current**

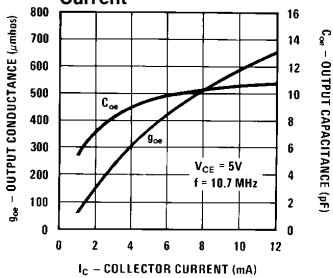

**g<sub>oe</sub> and C<sub>oe</sub> vs Collector Current**

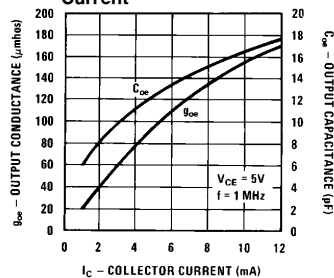

**Contours of Constant Noise Figure**

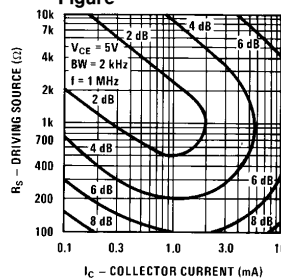

TL/H/7847-5

## Application Hints

### Gain Control

To make the LM389 a more versatile amplifier, two pins (4 and 12) are provided for gain control. With pins 4 and 12 open, the 1.35 k $\Omega$  resistor sets the gain at 20 (26 dB). If a capacitor is put from pin 4 to 12, bypassing the 1.35 k $\Omega$  resistor, the gain will go up to 200 (46 dB). If a resistor is placed in series with the capacitor, the gain can be set to any value from 20 to 200. A low frequency pole in the gain response is caused by the capacitor working against the external resistor in series with the 150 $\Omega$  internal resistor. If the capacitor is eliminated and a resistor connects pin 4 to 12, then the output dc level may shift due to the additional dc gain. Gain control can also be done by capacitively coupling a resistor (or FET) from pin 12 to ground.

Additional external components can be placed in parallel with the internal feedback resistors to tailor the gain and frequency response for individual applications. For example, we can compensate poor speaker bass response by frequency shaping the feedback path. This is done with a series RC from pin 1 to 12 (paralleling the internal 15 k $\Omega$  resistor). For 6 dB effective bass boost:  $R \cong 15$  k $\Omega$ , the lowest value for good stable operation is  $R = 10$  k $\Omega$  if pin 4 is open. If pins 4 and 12 are bypassed then R as low as 2 k $\Omega$  can be used. This restriction is because the amplifier is only compensated for closed-loop gains greater than 9V/V.

### Input Biasing

The schematic shows that both inputs are biased to ground with a 50 k $\Omega$  resistor. The base current of the input transistors is about 250 nA, so the inputs are at about 12.5 mV when left open. If the dc source resistance driving the LM389 is higher than 250 k $\Omega$  it will contribute very little additional offset (about 2.5 mV at the input, 50 mV at the output). If the dc source resistance is less than 10 k $\Omega$ , then shorting the unused input to ground will keep the offset low (about 2.5 mV at the input, 50 mV at the output). For dc source resistances between these values we can eliminate excess offset by putting a resistor from the unused input to ground, equal in value to the dc source resistance. Of course all offset problems are eliminated if the input is capacitively coupled.

When using the LM389 with higher gains (bypassing the 1.35 k $\Omega$  resistor between pins 4 and 12) it is necessary to

bypass the unused input, preventing degradation of gain and possible instabilities. This is done with a 0.1  $\mu$ F capacitor or a short to ground depending on the dc source resistance of the driven input.

### Supplies and Grounds

The LM389 has excellent supply rejection and does not require a well regulated supply. However, to eliminate possible high frequency stability problems, the supply should be decoupled to ground with a 0.1  $\mu$ F capacitor. The high current ground of the output transistor, pin 18, is brought out separately from small signal ground, pin 17. If the two ground leads are returned separately to supply then the parasitic resistance in the power ground lead will not cause stability problems. The parasitic resistance in the signal ground can cause stability problems and it should be minimized. Care should also be taken to insure that the power dissipation does not exceed the maximum dissipation of the package for a given temperature. There are two ways to mute the LM389 amplifier. Shorting pin 3 to the supply voltage, or shorting pin 12 to ground will turn the amplifier off without affecting the input signal.

### Transistors

The three transistors on the LM389 are general purpose devices that can be used the same as other small signal transistors. As long as the currents and voltages are kept within the absolute maximum limitations, and the collectors are never at a negative potential with respect to pin 17, there is no limit on the way they can be used.

For example, the emitter-base breakdown voltage of 7.1V can be used as a zener diode at currents from 1  $\mu$ A to 5 mA. These transistors make good LED driver devices,  $V_{SAT}$  is only 150 mV when sinking 10 mA.

In the linear region, these transistors have been used in AM and FM radios, tape recorders, phonographs and many other applications. Using the characteristic curves on noise voltage and noise current, the level of the collector current can be set to optimize noise performance for a given source impedance. Some of the circuits that have been built are shown in Figures 1-7. This is by no means a complete list of applications, since that is limited only by the designers imagination.

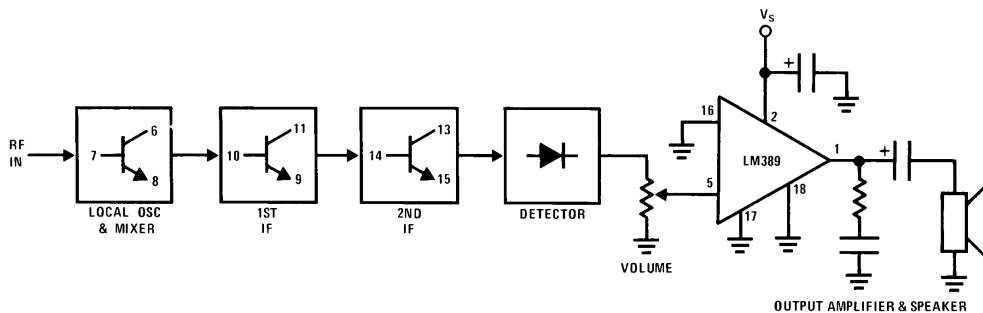

FIGURE 1. AM Radio

TL/H/7847-6

## Application Hints (Continued)

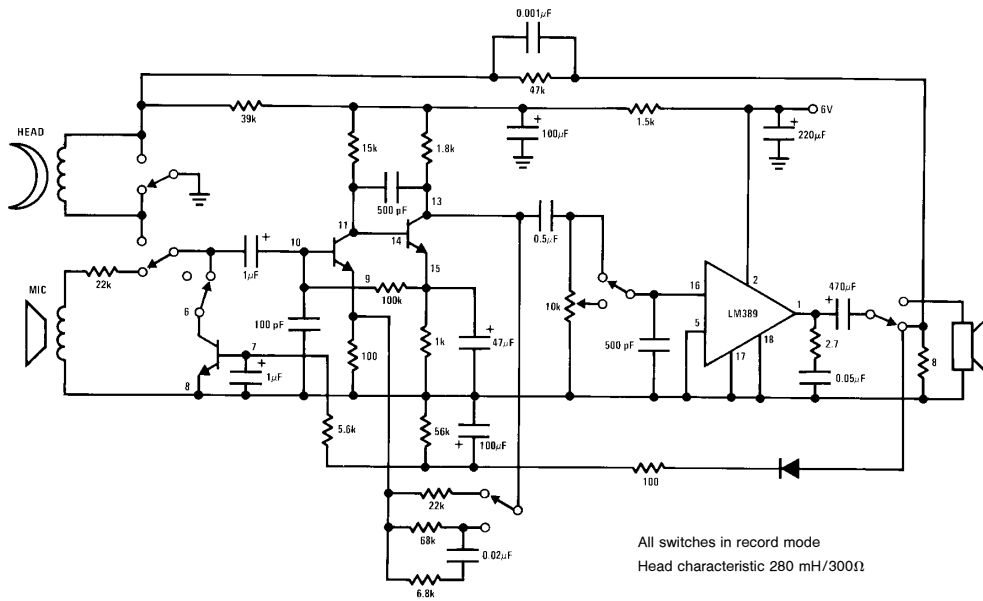

FIGURE 2. Tape Recorder

TL/H/7847-7

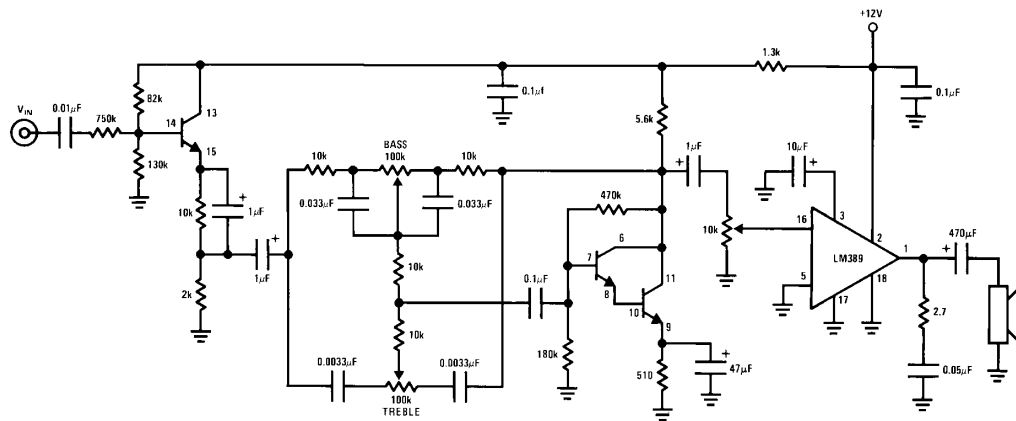

FIGURE 3. Ceramic Phono Amplifier with Tone Controls

TL/H/7847-8

### Application Hints (Continued)

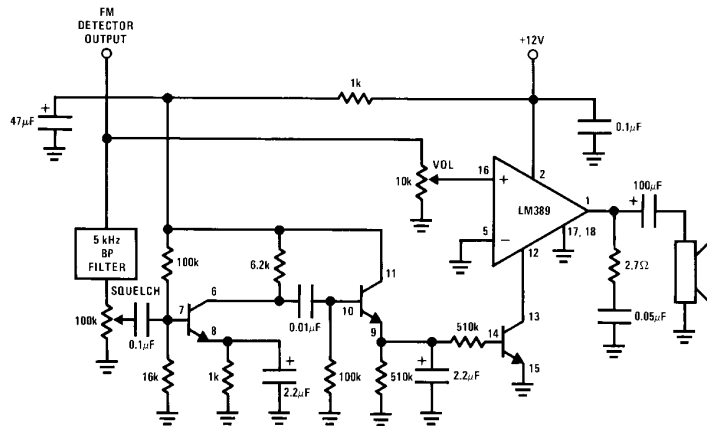
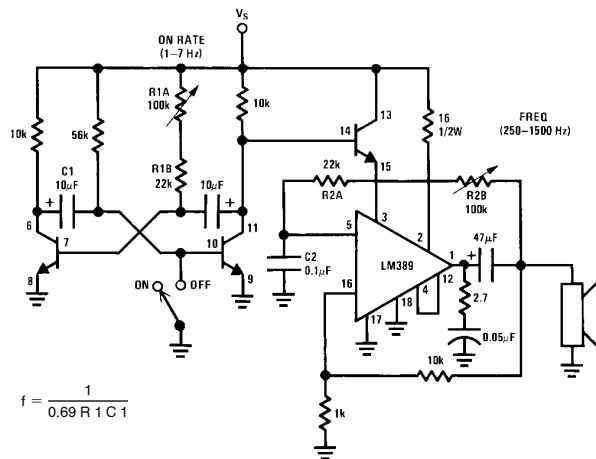

FIGURE 4. FM Scanner Noise Squelch Circuit

TL/H/7847-9



$$f = \frac{1}{0.69 R_1 C_1}$$

FIGURE 5. Siren

TL/H/7847-10

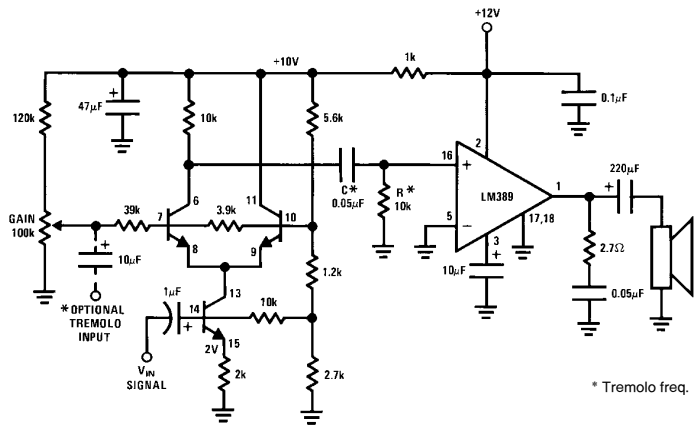

$$* \text{Tremolo freq.} \leq \frac{1}{2\pi (R + 10k)C}$$

FIGURE 6. Voltage-Controlled Amplifier or Tremolo Circuit

TL/H/7847-11

**Application Hints** (Continued)

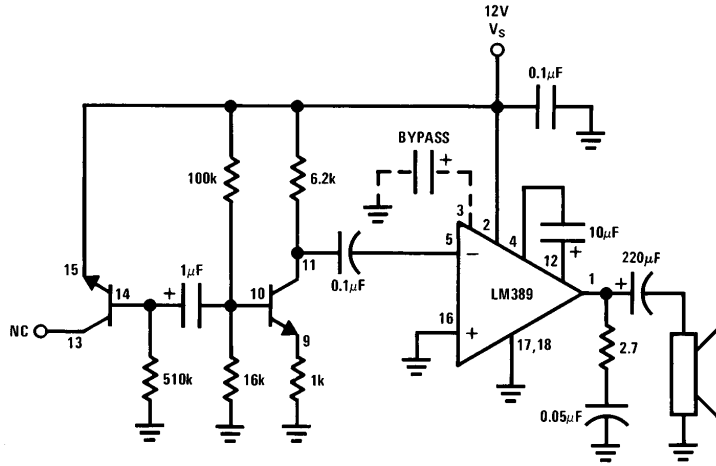

**FIGURE 7. Noise Generator Using Zener Diode**

TL/H/7847-12

**Physical Dimensions** inches (millimeters)

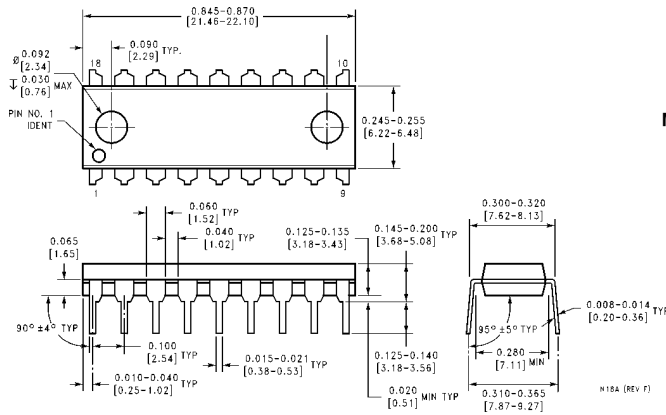

**Molded Dual-In-Line Package (N)**  
**Order Number LM389N**  
**NS Package Number N18A**

**LIFE SUPPORT POLICY**

NATIONAL'S PRODUCTS ARE NOT AUTHORIZED FOR USE AS CRITICAL COMPONENTS IN LIFE SUPPORT DEVICES OR SYSTEMS WITHOUT THE EXPRESS WRITTEN APPROVAL OF THE PRESIDENT OF NATIONAL SEMICONDUCTOR CORPORATION. As used herein:

1. Life support devices or systems are devices or systems which, (a) are intended for surgical implant into the body, or (b) support or sustain life, and whose failure to perform, when properly used in accordance with instructions for use provided in the labeling, can be reasonably expected to result in a significant injury to the user.
2. A critical component is any component of a life support device or system whose failure to perform can be reasonably expected to cause the failure of the life support device or system, or to affect its safety or effectiveness.

 <p><b>National Semiconductor Corporation</b>          1111 West Bardin Road          Arlington, TX 76017          Tel: (800) 272-9959          Fax: (800) 737-7018</p>	<p><b>National Semiconductor Europe</b></p> <p>Fax: (+49) 0-180-530 85 86          Email: cnjwge@tevm2.nsc.com          Deutsch Tel: (+49) 0-180-530 85 85          English Tel: (+49) 0-180-532 78 32          Français Tel: (+49) 0-180-532 93 58          Italiano Tel: (+49) 0-180-534 16 80</p>	<p><b>National Semiconductor Hong Kong Ltd.</b>          19th Floor, Straight Block,          Ocean Centre, 5 Canton Rd.          Tsimshatsui, Kowloon          Hong Kong          Tel: (852) 2737-1600          Fax: (852) 2736-9960</p>	<p><b>National Semiconductor Japan Ltd.</b>          Tel: 81-043-299-2309          Fax: 81-043-299-2408</p>
--	--	---	---

National does not assume any responsibility for use of any circuitry described, no circuit patent licenses are implied and National reserves the right at any time without notice to change said circuitry and specifications.