

- Integrated pressure sensor
- 300-1100hpa absolute Pressure Range
- ROHS compliant
- 11 coefficients for software compensation stored on chip
- Full integration of 2-axis magnetic sensors and electronics circuits resulting in less external components needed.
- I<sup>2</sup>C Slave, FAST (=400 KHz) mode
- Power up/down function available through I<sup>2</sup>C interface
- 2.4V~5.25V wide power supply operation supported
- SET/RESET strap drive
- 512counts/gauss

## Description

HDPM01 module includes a pressure module and a compass module

The HDPM01 pressure module includes a piezo-resistive pressure sensor and an ADC interface. It provides 16 bit word data for pressure and temperature related voltage. With the help of a highly accurate calibration of the sensor, 11 unique coefficients were stored on the chip, thus accurate pressure and temperature reading can be realized. HM03 is a low power, low voltage device with automatic power down switching. I<sup>2</sup>C Serial Interface is used for communications with a microprocessor. Sensor packaging options are SMD (with metal cap)

The HDPM01 is a dual-axis magnetic sensor, it is a complete sensing system with on-chip signal processing and integrated I<sup>2</sup>C bus, allowing the device to be connected directly to a microprocessor eliminating the need for A/D converters or timing resources. It can measure magnetic field with a full range of  $\pm 2$  gauss and a sensitivity of 512counts/gauss @3.0 V at 25°C.

## Features

- Supply voltage 2.2v-3.6v
- -20°C to + 60°C operating range
- No external components required
- I<sup>2</sup>C digital output with 400 KHz, fast mode operation.

## Applications

- Pressure measurement and control systems
- Mobile altimeter/barometer systems
- Weather forecast products
- Adventure or multi-mode watches
- Electronic Compass
- GPS Navigation
- Position Sensing
- Vehicle Detection
- Magnetometry

**1. Block Diagram**

**1.1 Block Diagram of the pressure module**

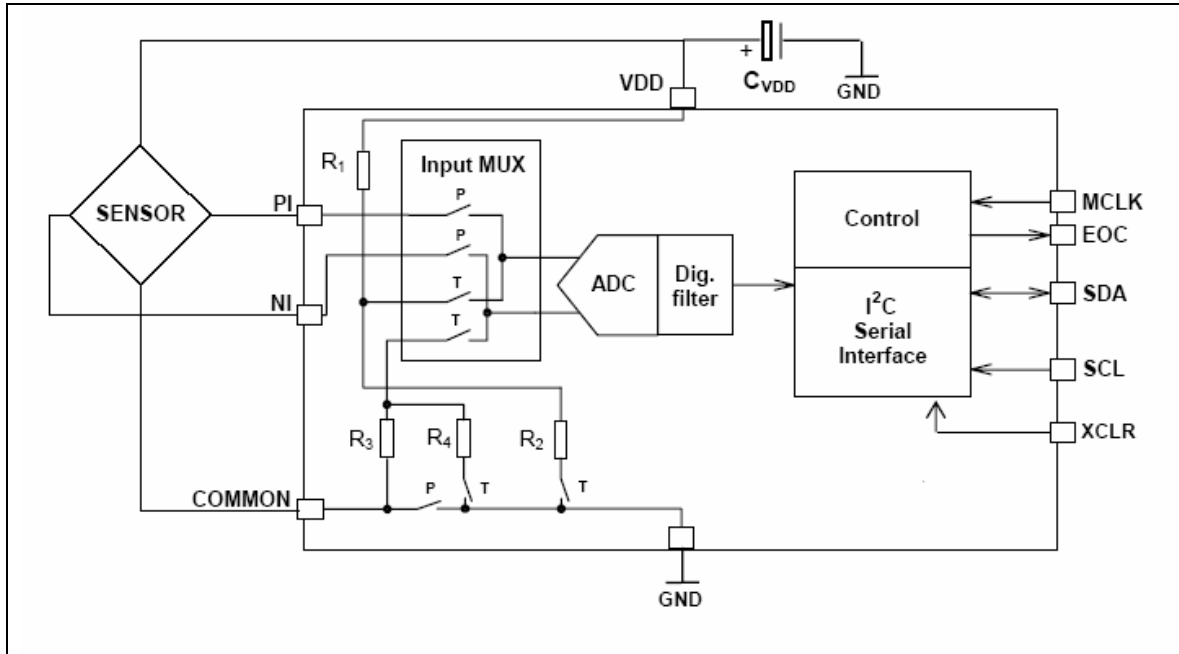

**1.2 Block Diagram of the compass module**

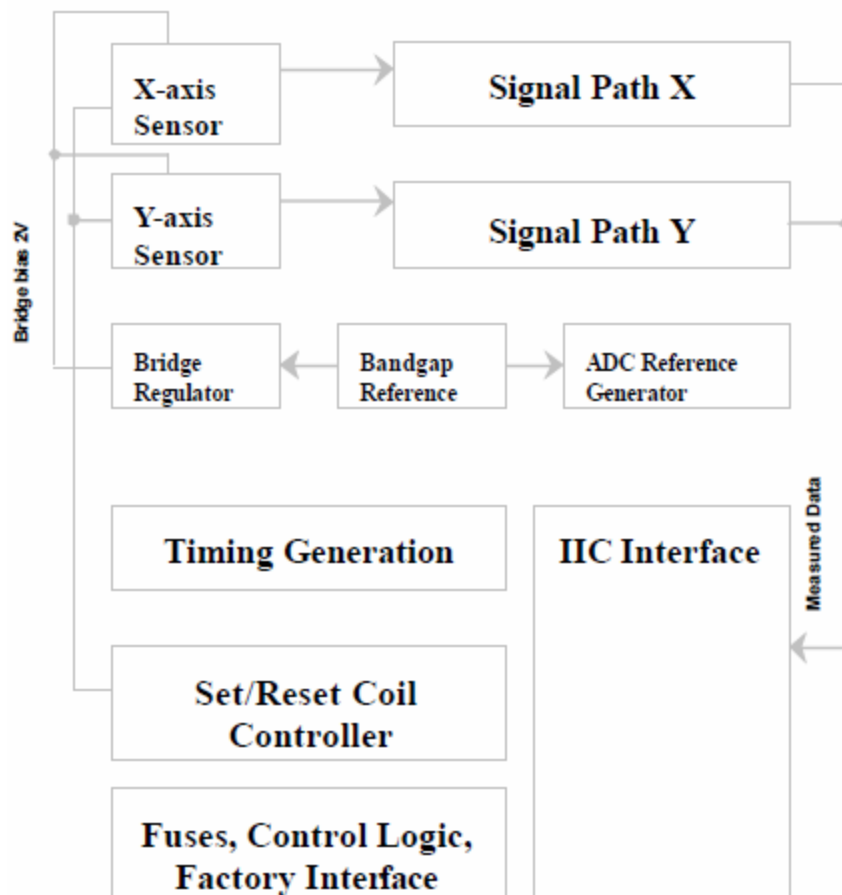

## 2. PIN Description

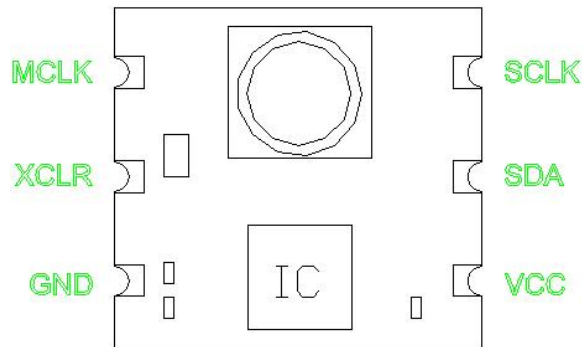

Pin Name	Pin Number	Type	Function
GND	6	G	power ground
VDD	5	P	power VCC
MCLK	4	I	master clock(32k) input
XCLR	3	I	ADC reset input (keep low when system is in idle state)
SDA	2	I/O	. I <sup>2</sup> C data input and output
SCL	1	I	I <sup>2</sup> C clock input

\* XCLR is to reset the AD converter (active low). XCLR should be set to high only during AD conversion phase(reading D1,D2), at all other states, such as reading calibration factors, this pin should be kept low.

\* The quality of the MCLK signal can significantly influence the current consumption of the pressure module. To obtain minimum current, remember to supply good quality MCLK signal

## 3. Absolute Maximum Ratings

Parameter	Symbol	Min	Max	Unit
Supply Voltage	VDD	-0.5	4	V
Over pressure	P		15	Bar(abs)
Storage Temperature	Tstg	-30	90	°C
Maximum Exposed Field			10000	gauss

**4. Recommended Operating Conditions**
**4.1 Recommended Operating Conditions of pressure**

Parameter	Symbol	Conditions	Min	Typ	Max	Unit
Supply Voltage	VDD		2.4	3	3.6	V
Supply Current during conversion	I	VDD=3V		500		V
Stand by				2		
Operating Pressure Range	P		300		1100	hpa (abs)
Operating Temperature Range	T	HDPM01	-20	25	60	°C
			TBD		60	°C
MCLK	T		30	32768	35	KHz
Duty Cycle of MCLK			40%	50%	60%	%
Serial Date Rate	SCL				400	KHz

## 4.2 Recommended Operating Conditions of compass

(Measurements @ 25°C, unless otherwise noted; VDA = VDD= 3.0V unless otherwise specified)

Parameter	Conditions	Min	Typ	Max	Units
Field Range (Each Axis)	Total applied field	-2		+2	gauss
Supply Voltage	V <sub>DA</sub> <sup>1</sup>	2.4	3.0	3.6	V
	V <sub>DD</sub> (I <sup>2</sup> C interface)	1.62	3.0	5.25	V
Supply Current	50 measurements/second		0.4		mA
Power Down Current				2	µA
Operating Temperature		-20		65	°C
Storage Temperature		-30		90	°C
Linearity Error (Best fit straight line)	±1 gauss		0.1		%FS
	±2 gauss		0.5		%FS
Hysteresis	3 sweeps across ±2 gauss		0.05		%FS
Repeatability Error	3 sweeps across ±2 gauss		0.1		%FS
Alignment Error			±1.0	±3.0	degrees
Transverse Sensitivity			±2.0	±5.0	%
Noise Density	1~25Hz, RMS		600		µgauss
Accuracy <sup>2</sup>			±2	±5	deg
Bandwidth			25		Hz
Sensitivity		-10		+10	%
		461	512	563	counts/gauss
Sensitivity Change Over Temperature	Based on 512counts/gauss		±1100		ppm/°C
Null Field Output		-0.2		+0.2	gauss
			2048		counts
Null Field Output Change Over Temperature	Without Set/Reset Delta from 25°C		±0.4		mgauss/°C
	With Set/Reset <sup>3</sup> Delta from 25°C		1/50		Ratio to the result without set/reset
Disturbing Field	Sensitivity start to degrade, use Set/Reset pulse to restore	5.5			gauss
Maximum Exposed Field				10000	gauss

- Note:** 1: 2.4V is the minimum operation voltage, or VDA should not be lower than 2.4V.  
 2: Accuracy is dependent on system design, calibration and compensation algorithms used.  
 The specification is based upon using the HOPERF evaluation board and associate software.  
 3: By design.

## 5. Pressure and Temperature Output Characteristics

With the calibration data provided by the HDPM01 system, it should be able to reach the following characteristics:

Parameter	Symbol	Conditions	Min	Typ	Max	Unit
Resolution			0.1			hpa
Relative Pressure Accuracy		750-1100	-2		2	hpa
Absolute Pressure Accuracy		750-1100	-3		3	hpa
Maximum Error Over Temperature		-20~+60	-5		5	hpa
Long Term Stability		12 month		2		hpa
VDD Dependency		2.4~3.6	-1.5	0	1.5	hpa
Temperature Accuracy			-1		1	°C

### I<sup>2</sup>C INTERFACE I/O CHARACTERISTICS (VDD=3.0V)

Parameter	Symbol	Test Condition	Min.	Typ.	Max.	Unit
Logic Input Low Level	$V_{IL}$		-0.5		$0.3 \cdot V_{DD}$	V
Logic Input High Level	$V_{IH}$		$0.7 \cdot V_{DD}$		$V_{DD}$	V
Hysteresis of Schmitt input	$V_{mys}$		0.2			V
Logic Output Low Level	$V_{OL}$				0.4	V
Input Leakage Current	$I_I$	$0.1V_{DD} < V_{in} < 0.9V_{DD}$	-10		10	$\mu A$
SCL Clock Frequency	$f_{SCL}$		0		400	kHz
START Hold Time	$t_{HD;STA}$		0.6			$\mu s$
START Setup Time	$t_{SU;STA}$		0.6			$\mu s$
LOW period of SCL	$t_{LOW}$		1.3			$\mu s$
HIGH period of SCL	$t_{HIGH}$		0.6			$\mu s$
Data Hold Time	$t_{HD;DAT}$		0		0.9	$\mu s$
Data Setup Time	$t_{SU;DAT}$		0.1			$\mu s$
Rise Time	$t_r$	From $V_{IL}$ to $V_{IH}$			0.3	$\mu s$
Fall Time	$t_f$	From $V_{IH}$ to $V_{IL}$			0.3	$\mu s$
Bus Free Time Between STOP and START	$t_{BUF}$		1.3			$\mu s$
STOP Setup Time	$t_{SU;STO}$		0.6			$\mu s$

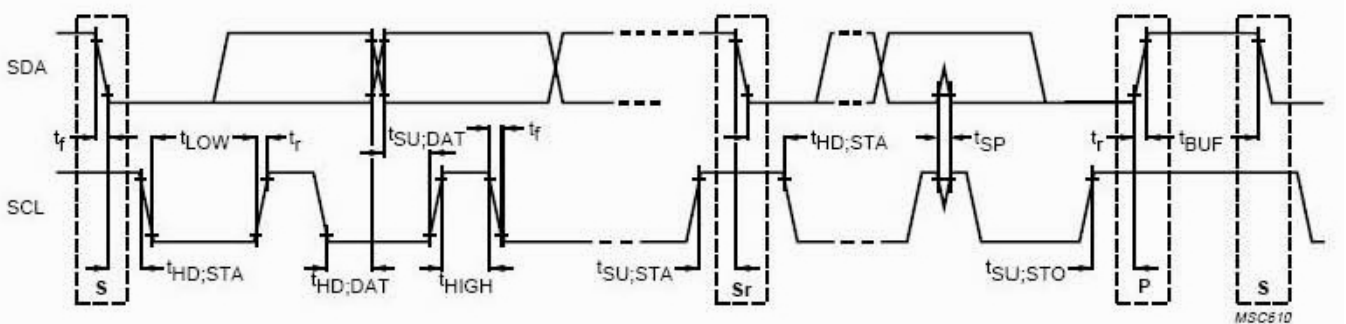

Timing Definition

## 6. Pressure and Temperature Measurement

The main function of HDPM01 system is to convert the uncompensated pressure and temperature signal from a pressure sensor. After the conversion, the following two values can be obtained:

- . measured temperature "D2"
- . measured pressure "D1"

As the sensor is strongly temperature dependent, it is necessary to compensate for these effects. Therefore 10 sensor-specific coefficients are stored on the HDPM01 at our manufacturing facility, and they allow an accurate software compensation in the application.

The 7 coefficients are:

- . Sensitivity coefficient "C1"
- . Offset coefficient "C2"
- . Temperature Coefficient of Sensitivity "C3"
- . Temperature Coefficient of Offset "C4"
- . Reference Temperature "C5"
- . Temperature Coefficient of Temperature "C6"
- . Offset Fine Tuning "C7"

4 sensor parameter

- . Sensor Specific Parameter "A,B,C,D"

Note: Make sure to pull low XCLR before start to Read these coefficients or the data read out is probably incorrect

Parameter Range(Hex:Dec)	
C1	0x100 -- 0x7FFF : 256 -- 65535
C2	0x00 -- 0xFFFF ; 0 -- 8191
C3	0x00 -- 0x400 ; 0 -- 3000
C4	0x00 -- 0x1000 ; 0 -- 4096
C5	0x1000 -- 0xFFFF ; 4096 -- 65535
C6	0x00 -- 0x4000 ; 0 -- 16384
C7	0x960 -- 0xA28 ; 2400 -- 2600
C,D	0x01 -- 0x0F ; 1 -- 15
A,B	0x01 -- 0x3F ; 1 -- 63
D1	0x00 -- 0xFFFF ; 0 -- 65535
D2	0x00 -- 0xFFFF ; 0 -- 65535

**Pressure and Temperature Calculation:**

Step 1: (get temperature value)

$D2 \geq C5$	$dUT = D2 - C5 - ((D2 - C5) / 2^7) * ((D2 - C5) / 2^7) * A / 2^C$
$D2 < C5$	$dUT = D2 - C5 - ((D2 - C5) / 2^7) * ((D2 - C5) / 2^7) * B / 2^C$

Step 2: (calculate offset, sensitivity and final pressure value)

$OFF = (C2 + (C4 - 1024) * dUT / 2^{14}) * 4$
---

$SENS = C1 + C3 * dUT / 2^{10}$
---------------------------------

$X = SENS * (D1 - 7168) / 2^{14} - OFF$
---

$P = X * 10 / 2^5 + C7$
-------------------------

- For altitude measurement system, recommend to use  $P = X * 100 / 2^5 + C7 * 10$
- So that better altitude resolution can be achieved

Step 3: (calculate temperature)

$T = 250 + dUT * C6 / 2^{16} - dUT / 2^D$
---

**Example:**

$C1 = 29908$

$C2 = 3724$

$C3 = 312$

$C4 = 441$

$C5 = 9191$

$C6 = 3990$

$C7 = 2500$

$A = 1$

$B = 4$

$C = 4$

$D = 9$

$D1 = 30036$

$D2 = 4107$

$$dUT = (4107 - 9191) - ((4107 - 9191) * (4107 - 9191) / 128^2) * 4 / 2^4 = -5478$$

$$OFF = (3724 + (441 - 1024) * (-5478) / 2^{14}) * 4 = 15675$$

$$SENS = 29908 + 312 * (-5478) / 2^{10} = 28238$$

$$X = 28238 * (30036 - 7168) / 2^{14} - 15675 = 23738$$

$$P = 23738 * 10 / 2^5 + 2500 = 9918 = 991.8 \text{ hpa}$$

$$T = 250 + (-5478) * 3990 / 2^{16} - (-5478 / 2^9) = -72 = -7.2^\circ\text{C}$$



## Serial Interface

The I<sup>2</sup>C interface is used for accessing calibration data as well as reading measurement result from AD conversion.

The EEPROM and ADC is sharing the same I<sup>2</sup>C bus but with different chip address assigned. The EEPROM chip address is set to 0xA1(in the case of read), write operation is not allowed. For AD part, the chip address is set to 0xEE. So this module used two different addresses for calibration data and AD converting data accessing. Calibration EEPROM data read operation is fully compatible to 24C02. Bus drive timing should be referred to the specification of this part as well.

Coefficient	EEPROM ADDRESS
C1(MSB:LSB)	(16:17)
C2(MSB:LSB)	(18:19)
C3(MSB:LSB)	(20:21)
C4(MSB:LSB)	(22:23)
C5(MSB:LSB)	(24:25)
C6(MSB:LSB)	(26:27)
C7(MSB:LSB)	(28:29)
A	(30)
B	(31)
C	(32)
D	(33)

**AD chip address is set to 0xEE(device write address), 0xEF(device read address). In order to get the AD value D1 and D2, you have to follow the following timing sequence:**

Pressure Measure:

S	1110111	0	A	1111111	1	A	1111000	0	A	P	D	S	1110111	0	A	1111110	1	A	S	1110111	1	A	MSB	A	LSB	N	P
---	---------	---	---	---------	---	---	---------	---	---	---	---	---	---------	---	---	---------	---	---	---	---------	---	---	-----	---	-----	---	---

Temperature Measure:

S	11101110	A	11111111	A	11101000	A	P	D	S	11101110	A	11111101	A	S	1110111	A	MSB	A	LSB	N	P
---	----------	---	----------	---	----------	---	---	---	---	----------	---	----------	---	---	---------	---	-----	---	-----	---	---

S: start condition

P: stop condition

**A ( bold )** : acknowledge from slave

A : acknowledge from master

N: no acknowledge from master (send out bit 1 instead)

D : delay for 40ms minimum

MSB: conversion result MSB

LSB: conversion result LSB.

**Remark:**

Before start an AD conversion cycle, remember to pull high for XCLR pin so that the system is no longer in the reset state.

All data read from the module is in hex format.

After first power on, the first read data should be disregarded, and only the second value should be used. This can assure that any unstable data after reset can be filtered out.

## 6.1. Compass measurement

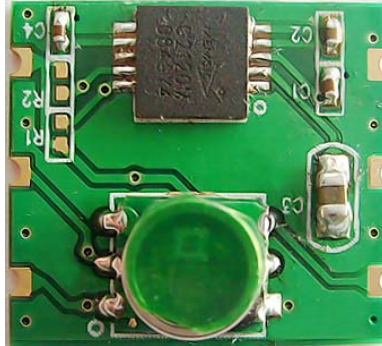

### **THEORY:**

The anisotropic magnetoresistive (AMR) sensors are special resistors made of permalloy thin film deposited on a silicon wafer. During manufacturing, a strong magnetic field is applied to the film to orient its magnetic domains in the same direction, establishing a magnetization vector. Subsequently, an external magnetic field applied perpendicularly to the sides of the film causes the magnetization to rotate and change angle. This in turn causes the film's resistance to vary. The HOPERF AMR sensor is included in a Wheatstone bridge, so that the change in resistance is detected as a change in differential voltage and the strength of the applied magnetic field may be inferred.

However, the influence of a strong magnetic field (more than 5.5 gauss) along the magnetization axis could upset, or flip, the polarity of the film, thus changing the sensor characteristics. A strong restoring magnetic field must be applied momentarily to restore, or set, the sensor characteristics. The HOPERF magnetic sensor has an on-chip magnetically coupled strap: a SET/RESET strap pulsed with a high current, to provide the restoring magnetic field.

**TYPICAL CHARACTERISTICS, % OF UNITS (@ 25°C, VDA = 3V)**

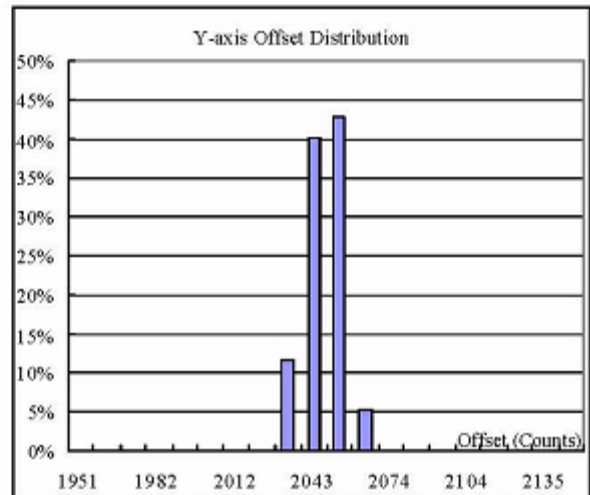
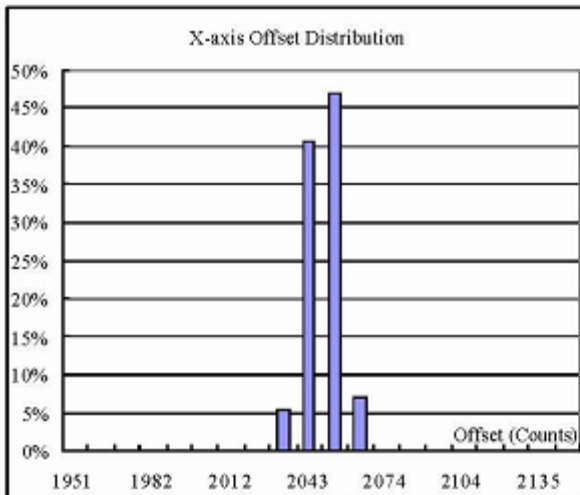
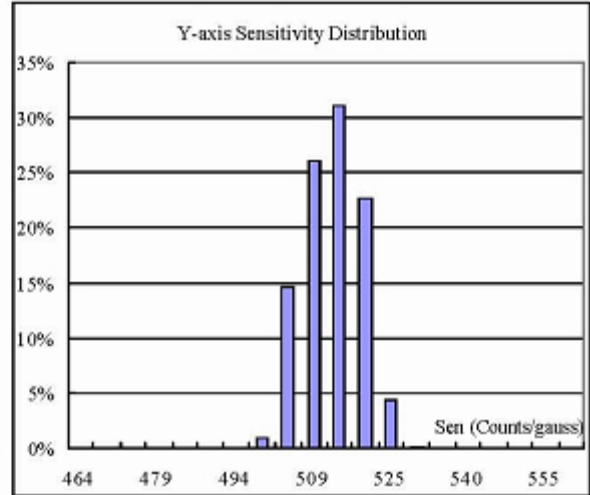
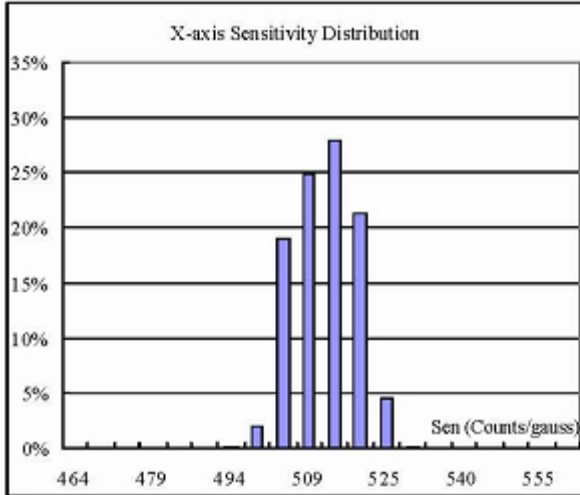

**OVER TEMPERATURE CHARACTERISTICS**

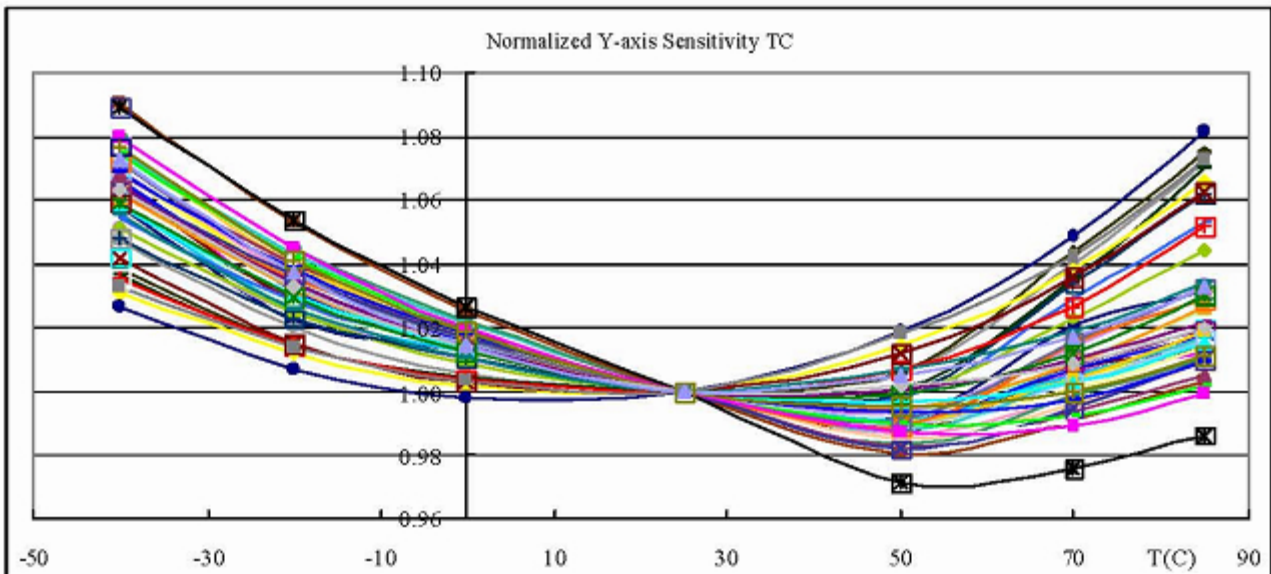
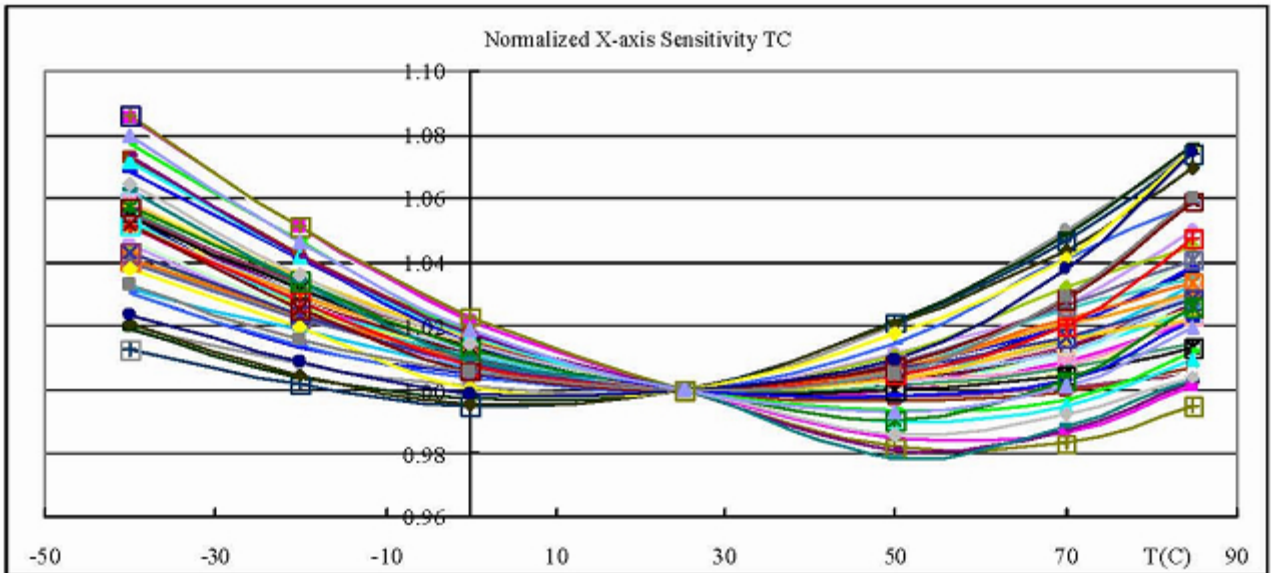

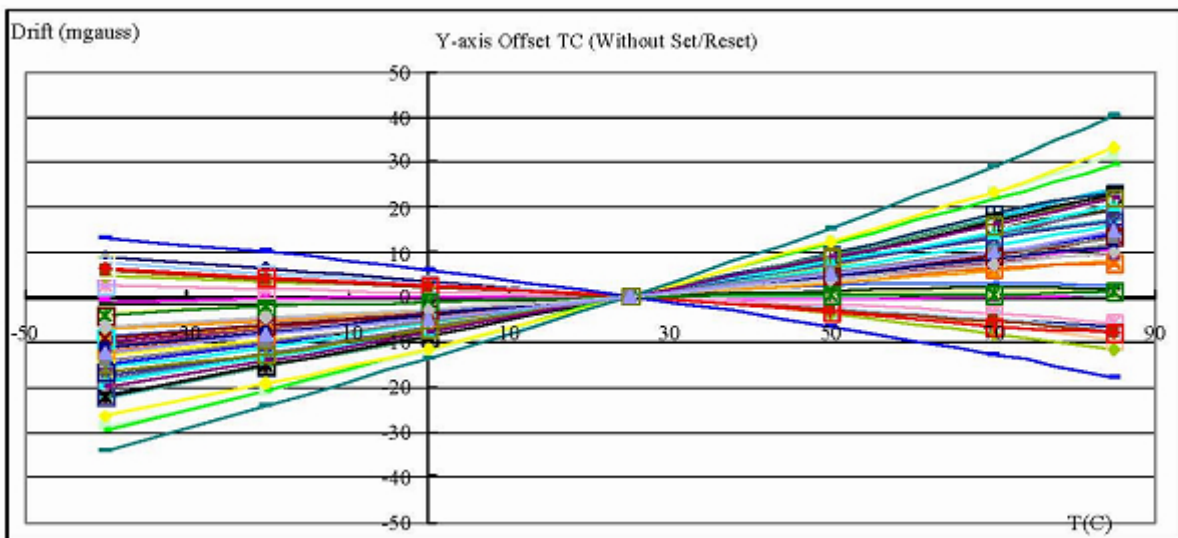
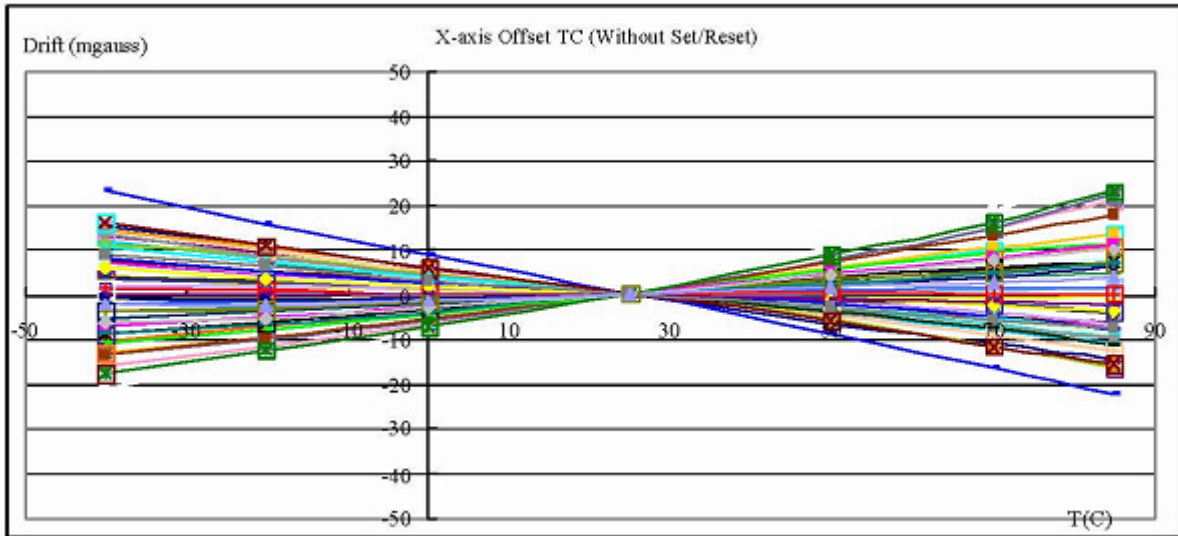

**POWER CONSUMPTION**

The HOPERF magnetic sensor consumes 0.4mA (typical) current at 3V with 50 measurements/second, but the current is proportional to the measurements carried out, for example, if only 20 measurements/second are performed, the current will be  $0.4 \times 20 / 50 = 0.16\text{mA}$ .

**I<sup>2</sup>C INTERFACE DESCRIPTION**

A slave mode I<sup>2</sup>C circuit has been implemented into the HOPERF magnetic sensor as a standard interface for customer applications. The A/D converter and MCU functionality have been added to the HOPERF sensor, thereby increasing ease-of-use, and lowering power consumption, footprint and total solution cost.

The I<sup>2</sup>C (or Inter IC bus) is an industry standard bi-directional two-wire interface bus. A master I2C device can operate READ/WRITE controls to an unlimited number of devices by device addressing. The HOPERF magnetic sensor operates only in a slave mode, i.e. only responding to calls by a master device.

**I<sup>2</sup>C BUS CHARACTERISTICS**

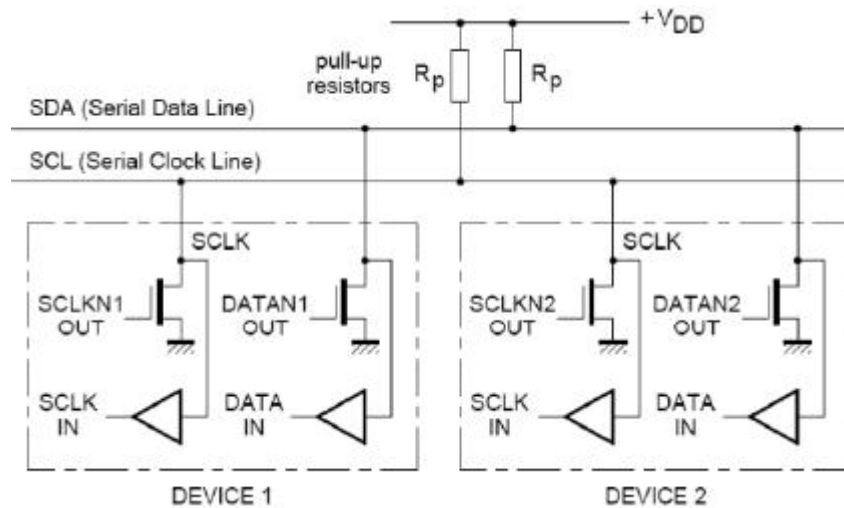

**I<sup>2</sup>C Bus**

The two wires in I<sup>2</sup>C bus are called SDA (serial data line) and SCL (serial clock line). In order for a data transfer to start, the bus has to be free, which is defined by both wires in a HIGH output state. Due to the open-drain/pull-up resistor structure and wired Boolean “AND” operation, any device on the bus can pull lines low and overwrite a HIGH signal. The data on the SDA line has to be stable during the HIGH period of the SCL line. In other words, valid data can only change when the SCL line is LOW. Note: Rp selection guide: 4.7Kohm for a short I<sup>2</sup>C bus length (less than 4inches), and 10Kohm for less than 2inches I<sup>2</sup>C bus.

**DATA TRANSFER**

A data transfer is started with a “START” condition and ended with a “STOP” condition. A “START” condition is defined by a HIGH to LOW transition on the SDA line while SCL line is HIGH. A “STOP” condition is defined by a LOW to HIGH transition on the SDA line while SCL line is HIGH. All data transfer in I2C system is 8-bits long. Each byte has to be followed by an acknowledge bit. Each data transfer involves a total of 9 clock cycles. Data is transferred starting with the most significant bit (MSB). After a “START” condition, master device calls specific slave device, in our case, a HOPERF device with a 7-bit device address “[0110xx0]”. To avoid potential address conflict, either by ICs from other manufacturers or by other HOPERF devices on the same bus, a total of 4 different addresses can be pre-programmed into HOPERF device by the factory. Following the 7-bit address, the 8th bit determines the direction of data transfer: [1] for READ and [0] for WRITE. After being addressed, available HOPERF device being called should respond by an “Acknowledge” signal, which is pulling SDA line LOW.

In order to read sensor signal, master device should operate a WRITE action with a code of [xxxxxx1] into HOPERF device 8-bit internal register. Note that this action also serves as a “wake-up” call.

Bit	Name	Function
0	TM (Take Measurements)	Initiate measurement sequence for “ 1” , this bit will be cleared by circuit outside of I2C core after measurement and A/D are finished. More specifically, it will be automatically cleared by TM_DONE signal after the action is finished.
1	SET (Set Coil)	Writing “ 1” will set the MR by passing a large current through Set/Reset Coil. It will be automatically cleared by SETRESET_DONE signal after the action is finished.
2	RESET (Reset Coil)	Writing “ 1” will reset the MR by passing a large current through Set/Reset Coil in a reversed direction. It will be automatically cleared by SETRESET_DONE signal after the action is finished.
3	Reserved	
4	Reserved	
5	Reserved	
6	Reserved	

After writing code of [xxxxxxx1] into control register and a zero memory address pointer is also written, and if a “READ” command is received, the HOPERF device being called transfers 8-bit data to I2C bus. If “Acknowledge” by master device is received, HOPERF device will continue to transfer next byte. The same procedure repeats until 5 byte of data are transferred to master device. Those 5 bytes of data are defined as following:

1. Internal register
2. MSB X-axis
3. LSB X-axis
4. MSB Y-axis
5. LSB Y-axis

Even though each axis consists two bytes, which are 16bits of data, the actual resolution is limited 12bits. Unused MSB should be simply filled by “0”s.

## POWER DOWN MODE

HOPERF MR sensor will enter power down mode automatically after data acquisition is finished. A data acquisition is initiated when master writes in to the control register a code of [xxxxxxx1].

## EXAMPLE OF TAKE MEASUREMENT

First cycle: START followed by a calling to slave address [0110xx0] to WRITE (8th SCL, SDA keep low). [xx] is determined by factory programming, total 4 different addresses are available.

Second cycle: After a acknowledge signal is received by master device (HOPERF device pulls SDA line low during 9<sup>th</sup> SCL pulse), master device sends “[00000000]” as the target address to be written into. HOPERF device should acknowledge at the end (9th SCL pulse). Note: since HOPERF device has only one internal register that can be written into, so user should always indicate “[00000000]” as the write address.

Third cycle: Master device writes to internal HOPERF device memory the code “[00000001]” as a wake-up call to initiate a data acquisition. HOPERF device should send acknowledge.

A STOP command indicates the end of write operation.

A minimal 5ms wait should be given to HOPERF device to finish a data acquisition and return a valid output. The TM bit (Take Measurement bit in control register) will be automatically reset to “0” after data from A/D converter is ready. The transition from “1” to “0” of TM bit also indicates “data ready”. The device will go into sleep mode afterwards. Analog circuit will be powered off, but I<sup>2</sup>C portion will continue be active and data will not be lost.

Fourth cycle: Master device sends a START command followed by calling HOPERF device address with a WRITE (8<sup>th</sup> SCL, SDA keep low). A ‘Acknowledge’ should be send by HOPERF device at the end.

Fifth cycle: Master device writes to HOPERF device a “[00000000]” as the starting address to read from internal memory. Since “[00000000]” is the address of internal control register, reading from this address can serve as a verification operation to confirm the write command has been successful. Note: the starting address in principle can be any of the 5 addresses. For example, user can start read from address [00000001], which is X channel MSB.



Sixth cycle: Master device calls HOPERF device address with a READ (8th SCL cycle SDA line high). HOPERF device should acknowledge at the end. Seventh cycle: Master device cycles SCL line, first addressed memory data appears on SDA line. If in step 7, "[00000000]" was sent, internal control register data should appear (in the following steps, this case is assumed). Master device should send 'Acknowledge' at the end.

Eighth cycle: Master device continues cycle SCL line, next byte of internal memory should appear on SDA line (MSB of X channel). The internal memory address pointer automatically moves to the next byte. Master acknowledges.

Ninth cycle: LSB of X channel.

Tenth cycle: MSB of Y channel.

Eleventh cycle: LSB of Y channel.

Master ends communications by NOT sending 'Acknowledge' and also followed by a 'STOP' command.

### **EXAMPLE OF SET/RESET COIL**

First cycle: START followed by a calling to slave address [0110xx0] to WRITE (8<sup>th</sup> SCL, SDA keep low). [xx] is determined by factory programming, total 4 different addresses are available.

Second cycle: After a acknowledge signal is received by master device (HOPERF device pulls SDA line low during 9<sup>th</sup> SCL pulse), master device sends "[00000000]" as the target address to be written into. HOPERF device should acknowledge at the end (9th SCL pulse). Note: since HOPERF device has only one internal register can be written into, user should always use "[00000000]" as the write address.

Third cycle: Master device writes to internal HOPERF device memory a code "[00000010]" as a wake-up call to initiate a SET action, or a code "[00000100]" to initiate a RESET action. Note that in low voltage mode, master need to issue SET command if the previous command is RESET, and issue a RESET command if the previous command is SET. In the case of a cold start (device just powered on), master should only issue SET command. The wait time from power on to SET command should be a minimal 10ms. HOPERF device should send acknowledge. Note that SET and RESET bits should not be set to "1" at the same time. In case of that happens, the device will only do a SET action. A STOP command indicates the end of write operation.

A minimal 50us wait period should be given to HOPERF device to finish SET/RESET action before taking a measurement. The SET or RESET bit will be automatically reset to "0" after SET/RESET is done. And the device will go to sleep mode afterwards.

In low voltage operation mode, SET/RESET commands have to alternate. In other words, one can not do a SET following a SET, same for RESET. The first command after initial power up should be SET. If RESET command is attempted as the first command, it will be ignored. Between SET and RESET, a minimal 5ms need to be given for the voltage on capacitor to settle.

Note 1: at power-on, internal register and memory address pointer are reset to "0".

Note 2: In low voltage operation mode, device requires an additional capacitor to be able to do SET/RESET at lower supply voltage.

**Typical Application Circuit Diagram:**

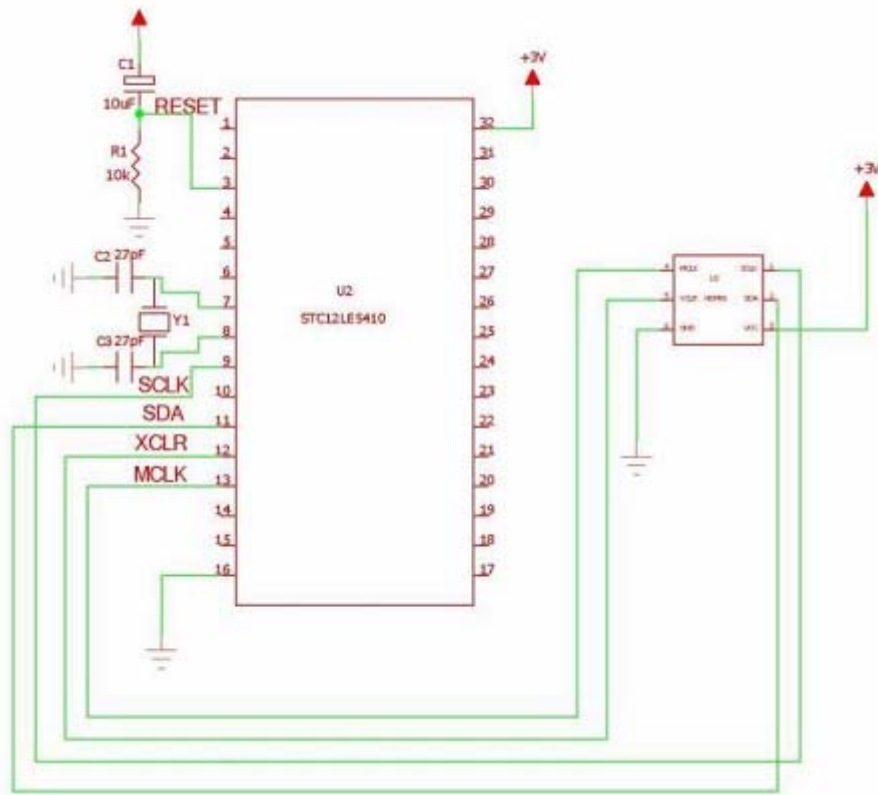

**Mechanical Dimension (mm)**

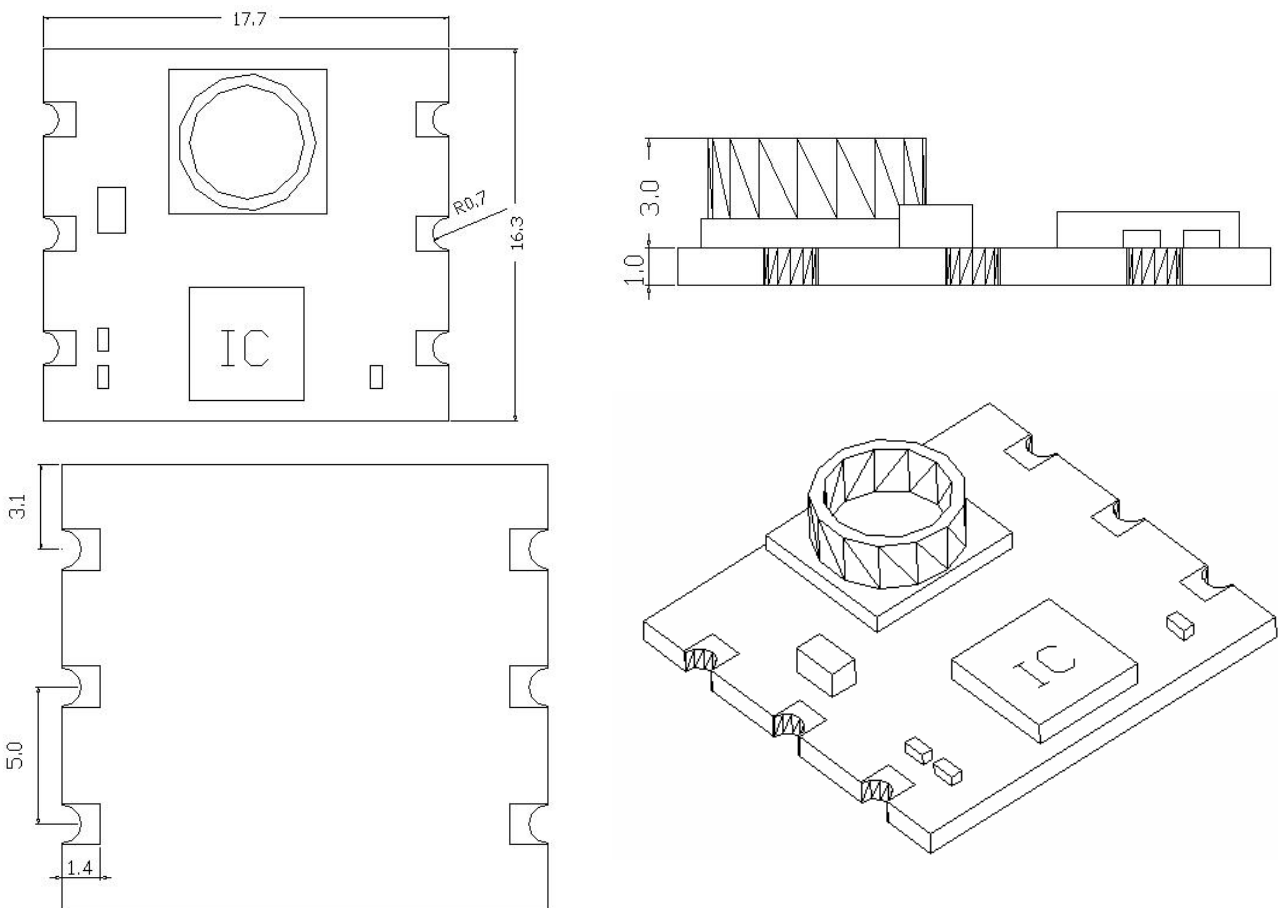

**Important Notices**

Never unplug the module when power is on.

Do not use this product as safety or emergency stop device or in any application where failure of this product could lead in personal injury. Failure to comply with these instructions could result with death or serious injury.

Should buyer purchase or use HOPE RF products for any such unintended or unauthorized application, buyer should indemnify and hold HOPE RF and its officers, employees, affiliates and distributors harmless against all claims, costs, damages and expenses, and reasonable attorney fees arising out of, directly or indirectly, any claim of personal injury associated with such unintended or unauthorized use, even if such claim alleges that HOPE RF was negligent regarding the design or manufacturing of the part.

Hope RF reserves the right, without further notice, to change the product specification and/or information in this document and to improve reliability, functions and design.