

Product Category: Waterproof

Category: Transceiver

Nominal frequency: $48.0 \pm 1.0\text{KHz}$

Sound pressure: 100dB min.

Sensitivity: -74dB min.

Static capacitance: $1600\text{Pf} \pm 20\%$

Yu Zhen: 1.2ms max.

Maximum input voltage: 150Vp-P

Direction angle: horizontal 70° / longitudinal $30^\circ \pm 15^\circ$ (-6dB)

Detection range: 0.2 ~ 3M (reflection)

Resolution: 10 mm

Operating temperature: $-40^\circ\text{C} \sim +80^\circ\text{C}$

Storage temperature: $-40^\circ\text{C} \sim +85^\circ\text{C}$

Housing material: Aluminum

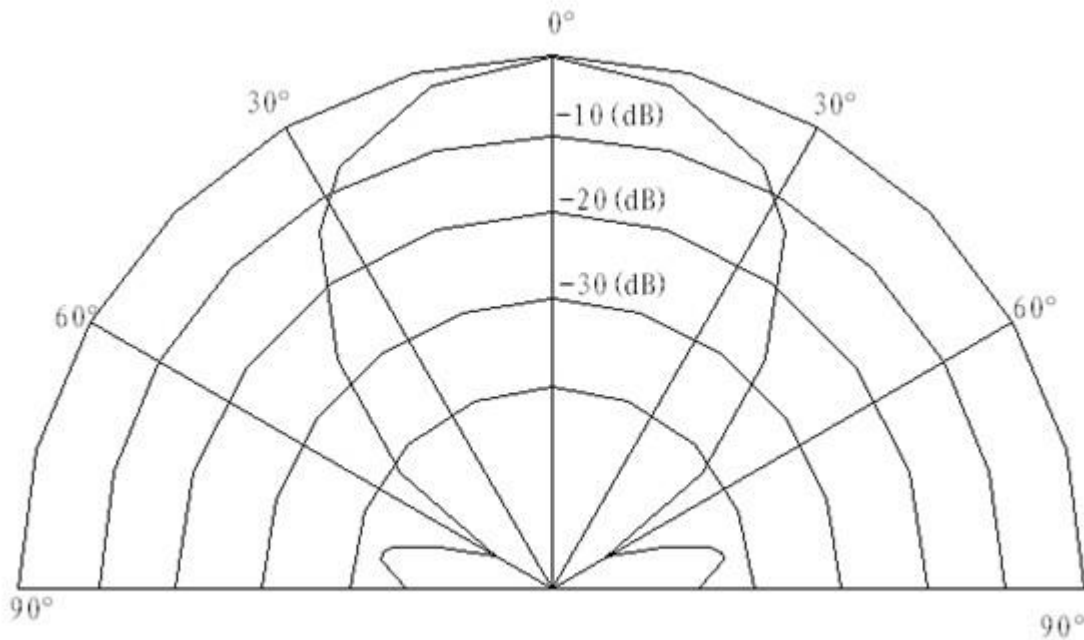

Directivity in Overall Sensitivity

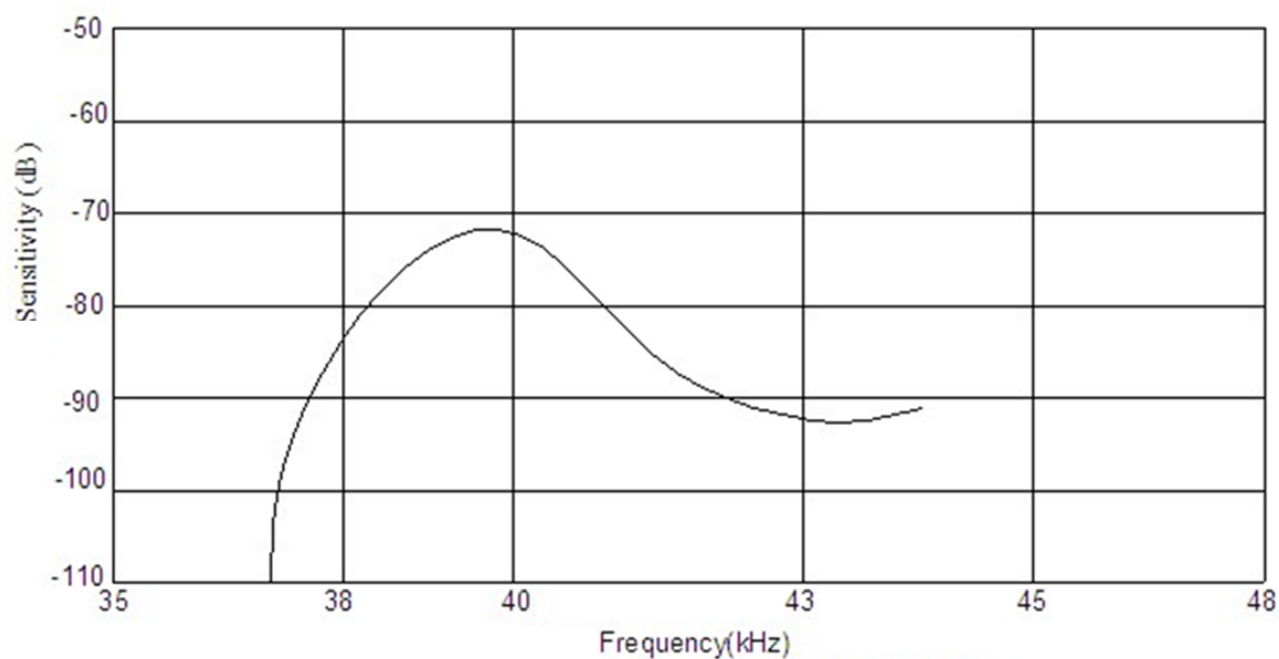

Frequency(kHz)
Sensitivity-Freq.Characteristics

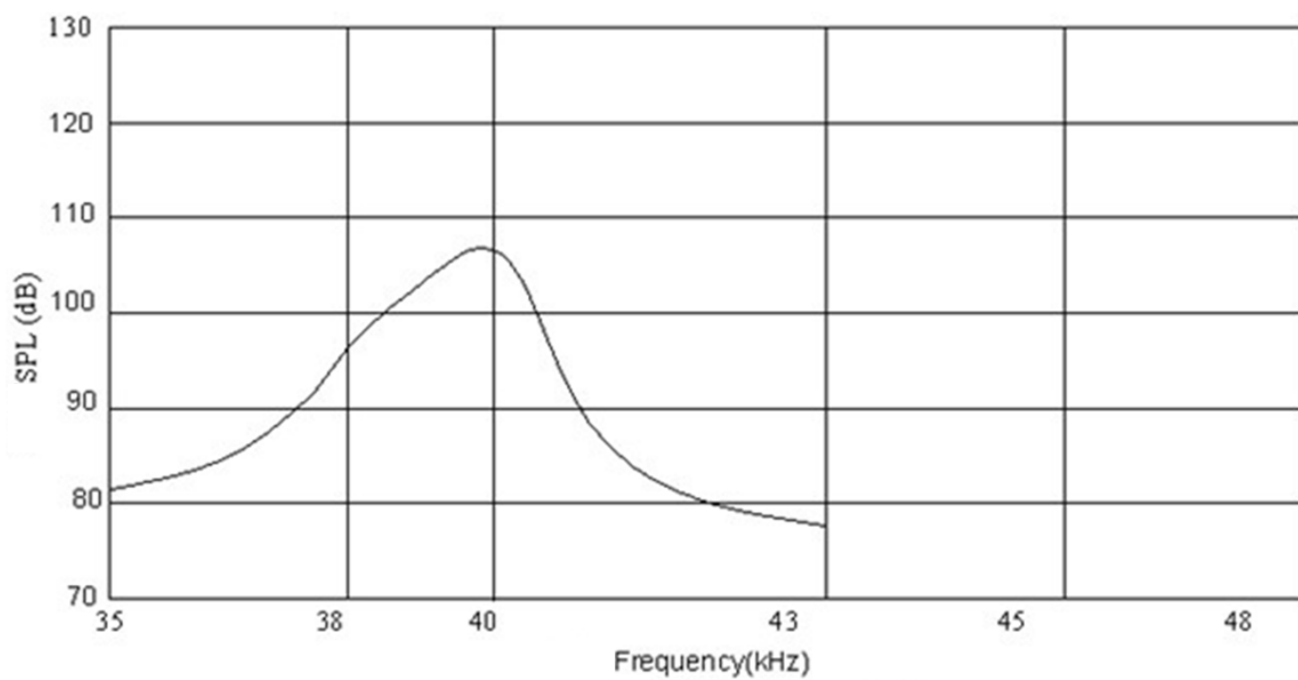

Frequency(kHz)
SPL-Freq.Characteristics