

Features

- Non-contact switching.
- For direct PC board or dual-in-line socket mounting.
- Fast switching speed.
- Reflective object sensor.

Application

- FAX machine
- Printer
- COPY machine
- Counter

Description

The LTH-209-01/LTH-1550-01/LTH-1650-01 reflective object sensors consist of an infrared emitting diode and a NPN silicon phototransistor mounted side by side on converging optical axis in a black plastic housing.

Package Dimensions

LTH-209-01

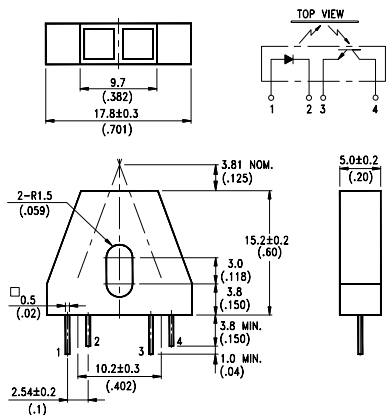

LTH-1550-01

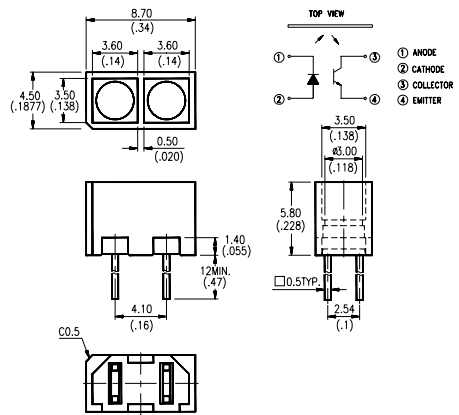

LTH-1650-01

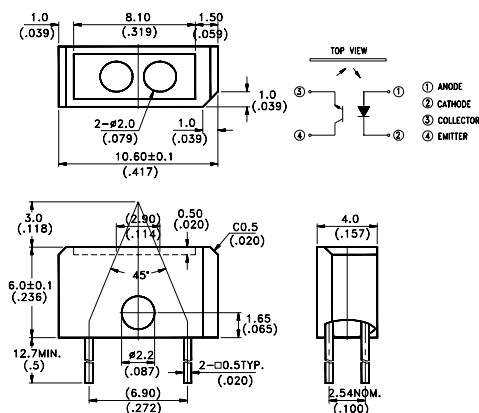

Notes:

1. All dimensions are in millimeters (inches).
2. Tolerance is ± 0.25 mm (.010").
3. Lead spacing is measured where the leads emerge from the package.
4. Specifications are subject to change without notice.

Absolute Maximum Rating at Ta=25°C

Parameter		Symbol	Maximum Rating	Unit
Input LED	Continuous Forward Current	I _F	60	mA
	Reverse Voltage	V _R	5	V
	Peak Forward Current (Pulse Wide=10 μs, 300PPS)	I _{CP}	1	A
	Power Dissipation	P _D	75	mW
Output phototransistor	Collector Current	I _C	20	mA
	Power Dissipation	P _C	100	mW
	Collector-emitter Voltage	V _{CEO}	30	V
	Emitter-collector Voltage	V _{ECO}	5	V
Operating Temperature Range		T _{opr}	-25°C to + 85°C	
Storage Temperature Range		T _{stg}	-40°C to + 100°C	
Lead Soldering Temperature [1.6mm(.063 in.)from body]		T _s	260°C for 5 Seconds	

Electrical Optical Characteristics at Ta=25°C

Parameter	Symbol	Part No.	Min.	Typ.	Max.	Unit	Test Condition	Bin No.	
Input LED									
Forward Voltage	V _F			1.2	1.6	V	I _F =20mA		
Reverse Current	I _R				100	μA	V _R =5V		
Output phototransistor									
Collector Dark Current	I _{CEO}				100	nA	V _{CE} =10V		
Coupler									
Collector-Emitter Saturation Voltage	V _{CE(sat)}	LTH-209-01			0.4	V	I _C =0.08mA, I _F =20mA		
		LTH-1550-01			0.4		I _C =0.10mA, I _F =20mA		
		LTH-1650-01			0.4		I _C =0.05mA, I _F =20mA		
On State Collector Current	I _{C(ON)}	LTH-209-01	160			μA	NOTE1		
			200	400	400			NOTE2	BINA
			300		600				BINB
		LTH-1550-01	500		1000		BINC		
			800		1600		BIND		
			LTH-1650-01	100			300	NOTE3	BINA
		200			600		BINB		
		400			1200		BINC		
		Response Time	Rise Time	t _r			3	15	μs
Fall Time	t _f			4	20				

NOTE1: V_{CE}=5V, I_F=20mA, d=3.81MM, 90% Reflectance White Paper

NOTE2: V_{CE}=5V, I_F=20mA, d=3.50MM, 90% Reflectance White Paper

NOTE3: V_{CE}=5V, I_F=20mA, d=3.00MM, 90% Reflectance White Paper

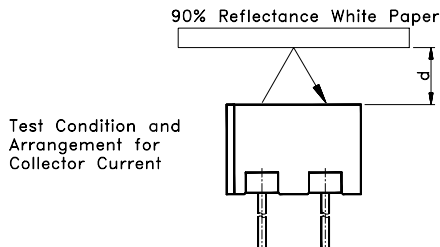

Typical Electrical/Optical Characteristic Curves (25°C Ambient Temperature Unless Otherwise Noted)

Fig.1 Power Dissipation vs. Ambient Temperature

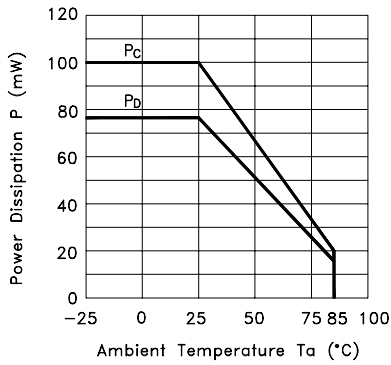

Fig.2 Forward Current vs. Forward Voltage

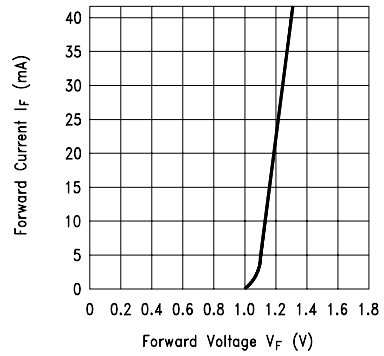

Fig.3 Collector Current vs. Collector-emitter Voltage

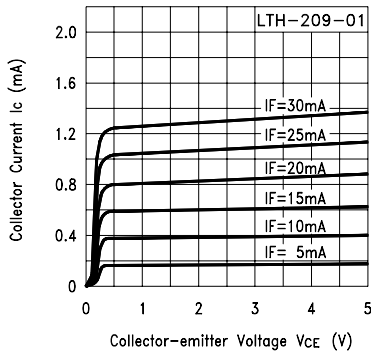

Fig.4 Collector Current vs. Collector-emitter Voltage

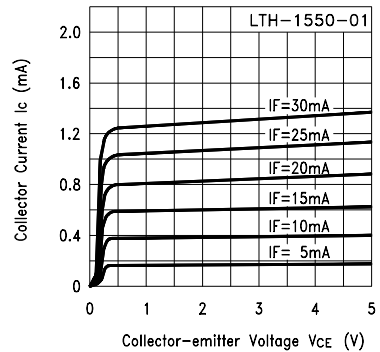

Fig.5 Collector Current vs. Collector-emitter Voltage

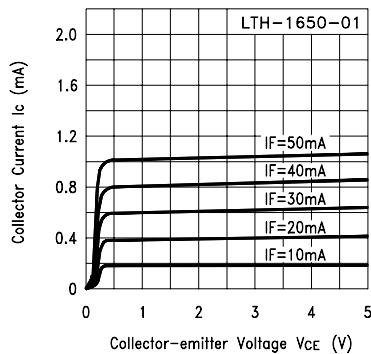
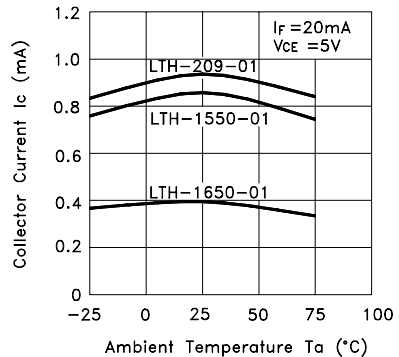

Fig.6 Collector Current vs. Ambient Temperature



Typical Electrical/Optical Characteristic Curves (25°C Ambient Temperature Unless Otherwise Noted)

Fig.7 Collector-emitter Saturation Voltage vs. Ambient Temperature

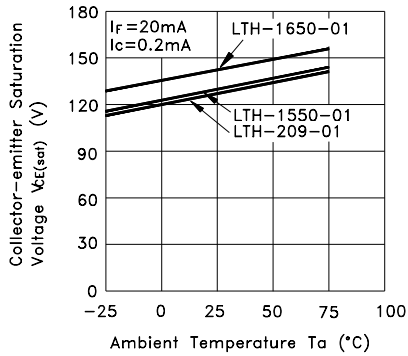

Fig.8 Relative Collector Current vs. Object Distance

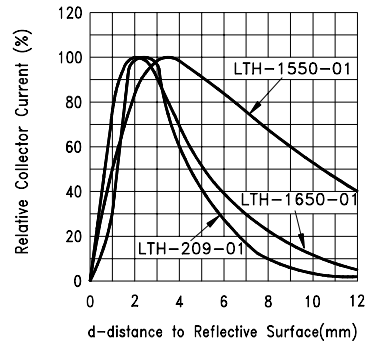
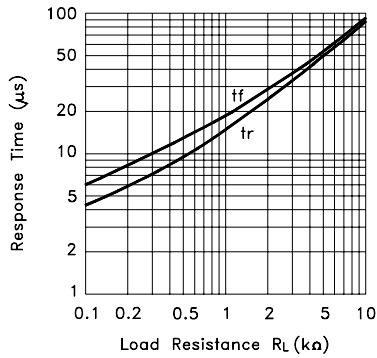

Fig.9 Response Time vs. Load Resistance



Test Circuit for Response Time

