

QUAD 2-INPUT NAND SCHMITT TRIGGER

FEATURES

- Output capability: standard
- I_{CC} category: SSI

GENERAL DESCRIPTION

The 74HC/HCT132 are high-speed Si-gate CMOS devices and are pin compatible with low power Schottky TTL (LSTTL). They are specified in compliance with JEDEC standard no. 7A.

The 74HC/HCT132 contain four 2-input NAND gates which accept standard input signals. They are capable of transforming slowly changing input signals into sharply defined, jitter-free output signals.

The gate switches at different points for positive and negative-going signals. The difference between the positive voltage V_{T+} and the negative voltage V_{T-} is defined as the hysteresis voltage V_H.

SYMBOL	PARAMETER	CONDITIONS	TYPICAL		UNIT
			HC	HCT	
t _{PHL} / t _{PLH}	propagation delay nA, nB to nY	C _L = 15 pF V _{CC} = 5 V	11	17	ns
C _I	input capacitance		3.5	3.5	pF
C _{PD}	power dissipation capacitance per gate	notes 1 and 2	24	20	pF

GND = 0 V; T_{amb} = 25 °C; t_r = t_f = 6 ns

Notes

1. C_{PD} is used to determine the dynamic power dissipation (P_D in μW):

$$P_D = C_{PD} \times V_{CC}^2 \times f_i + \sum (C_L \times V_{CC}^2 \times f_o)$$
 where:
 f_i = input frequency in MHz C_L = output load capacitance in pF
 f_o = output frequency in MHz V_{CC} = supply voltage in V
 $\sum (C_L \times V_{CC}^2 \times f_o)$ = sum of outputs
2. For HC the condition is V_I = GND to V_{CC}
 For HCT the condition is V_I = GND to V_{CC} - 1.5 V

PACKAGE OUTLINES

14-lead mini-pack; plastic (SO14; SOT108A).
 16-lead DIL; plastic (SOT38Z).

PIN DESCRIPTION

PIN NO.	SYMBOL	NAME AND FUNCTION
1, 4, 9, 12	1A to 4A	data inputs
2, 5, 10, 13	1B to 4B	data inputs
3, 6, 8, 11	1Y to 4Y	data outputs
7	GND	ground (0 V)
14	V _{CC}	positive supply voltage

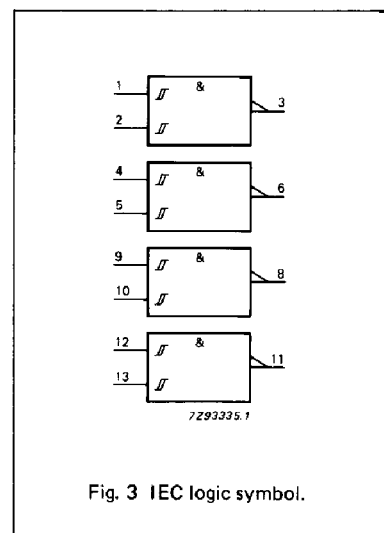
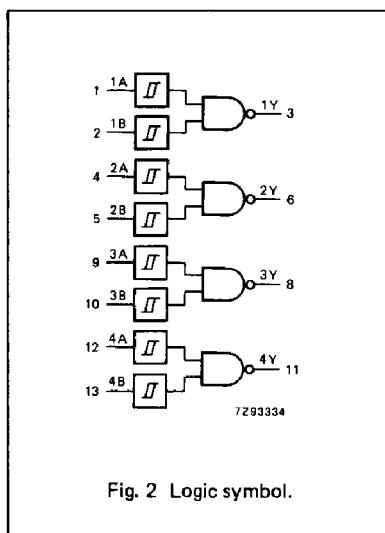
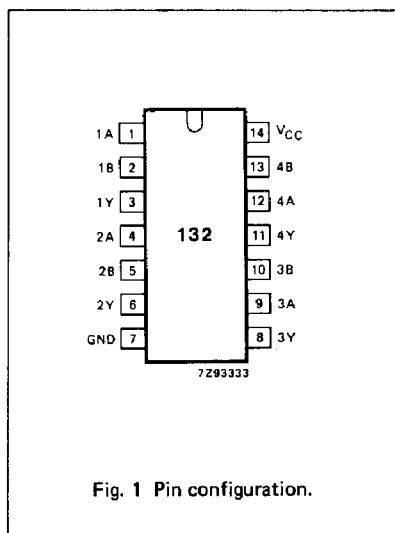

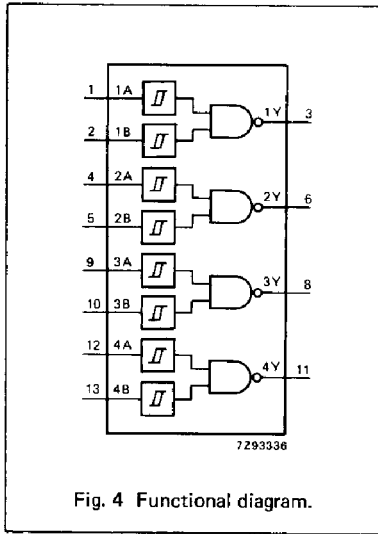

Fig. 4 Functional diagram.

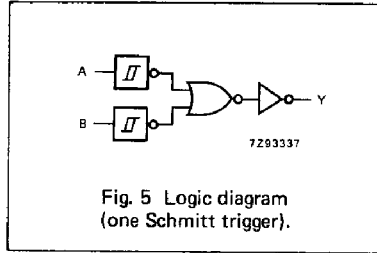

Fig. 5 Logic diagram
(one Schmitt trigger).

APPLICATIONS

- Wave and pulse shapers
- Astable multivibrators
- Monostable multivibrators

FUNCTION TABLE

INPUTS		OUTPUT
nA	nB	nY
L	L	H
L	H	H
H	L	H
H	H	L

H = HIGH voltage level
L = LOW voltage level

DC CHARACTERISTICS FOR 74HC

For the DC characteristics see chapter "HCMOS family characteristics", section "Family specifications". Transfer characteristics are given below.

Output capability: standard

I_{CC} category: SSI

Transfer characteristics for 74HC

Voltages are referenced to GND (ground = 0 V)

SYMBOL	PARAMETER	T _{amb} (°C)								UNIT	TEST CONDITIONS	
		74HC									V _{CC} V	WAVEFORMS
		+25			-40 to +85		-40 to +125					
		min.	typ.	max.	min.	max.	min.	max.				
V _{T+}	positive-going threshold	0.7 1.7 2.1	1.18 2.38 3.14	1.5 3.15 4.2	0.7 1.7 2.1	1.5 3.15 4.2	0.7 1.7 2.1	1.5 3.15 4.2	V	2.0 4.5 6.0	Figs 6 and 7	
V _{T-}	negative-going threshold	0.3 0.9 1.2	0.63 1.67 2.26	1.0 2.2 3.0	0.3 0.9 1.2	1.0 2.2 3.0	0.3 0.9 1.2	1.0 2.2 3.0	V	2.0 4.5 6.0	Figs 6 and 7	
V _H	hysteresis (V _{T+} - V _{T-})	0.2 0.4 0.6	0.55 0.71 0.88	1.0 1.4 1.6	0.2 0.4 0.6	1.0 1.4 1.6	0.2 0.4 0.6	1.0 1.4 1.6	V	2.0 4.5 6.0	Figs 6 and 7	

AC CHARACTERISTICS FOR 74HC

GND = 0 V; t_r = t_f = 6 ns; C_L = 50 pF

SYMBOL	PARAMETER	T _{amb} (°C)								UNIT	TEST CONDITIONS	
		74HC									V _{CC} V	WAVEFORMS
		+25			-40 to +85		-40 to +125					
		min.	typ.	max.	min.	max.	min.	max.				
t _{PHL} / t _{PLH}	propagation delay nA, nB to nY		36 13 10	125 25 21		155 31 26		190 38 32	ns	2.0 4.5 6.0	Fig. 13	
t _{THL} / t _{TLH}	output transition time		19 7 6	75 15 13		95 19 16		110 22 19	ns	2.0 4.5 6.0	Fig. 13	

74HC/HCT132
SSI

DC CHARACTERISTICS FOR 74HCT

For the DC characteristics see chapter "HCMOS family characteristics", section "Family specifications". Transfer characteristics are given below.

Output capability: standard
I_{CC} category: SSI

Note to HCT types

The value of additional quiescent supply current (ΔI_{CC}) for a unit load of 1 is given in the family specifications. To determine ΔI_{CC} per input, multiply this value by the unit load coefficient shown in the table below.

INPUT	UNIT LOAD COEFFICIENT
nA, nB	0.3

Transfer characteristics for 74HCT

Voltages are referenced to GND (ground = 0 V)

SYMBOL	PARAMETER	T _{amb} (°C)								UNIT	TEST CONDITIONS	
		74HCT									V _{CC} V	WAVEFORMS
		+25			-40 to +85		-40 to +125					
		min.	typ.	max.	min.	max.	min.	max.				
V _{T+}	positive-going threshold	1.2 1.4	1.41 1.59	1.9 2.1	1.2 1.4	1.9 2.1	1.2 1.4	1.9 2.1	V	4.5 5.5	Figs 6 and 7	
V _{T-}	negative-going threshold	0.5 0.6	0.85 0.99	1.2 1.4	0.5 0.6	1.2 1.4	0.5 0.6	1.2 1.4	V	4.5 5.5	Figs 6 and 7	
V _H	hysteresis (V _{T+} - V _{T-})	0.4 0.4	0.56 0.60	- -	0.4 0.4	- -	0.4 0.4	- -	V	4.5 5.5	Figs 6 and 7	

AC CHARACTERISTICS FOR 74HCT

GND = 0 V; t_r = t_f = 6 ns; C_L = 50 pF

SYMBOL	PARAMETER	T _{amb} (°C)								UNIT	TEST CONDITIONS	
		74HCT									V _{CC} V	WAVEFORMS
		+25			-40 to +85		-40 to +125					
		min.	typ.	max.	min.	max.	min.	max.				
t _{PHL} / t _{PLH}	propagation delay nA, nB to nY		20	33		41		50	ns	4.5	Fig. 13	
t _{THL} / t _{TLH}	output transition time		7	15		19		22	ns	4.5	Fig. 13	

TRANSFER CHARACTERISTIC WAVEFORMS

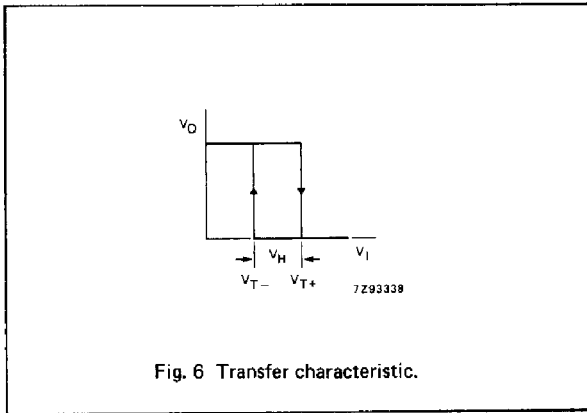

Fig. 6 Transfer characteristic.

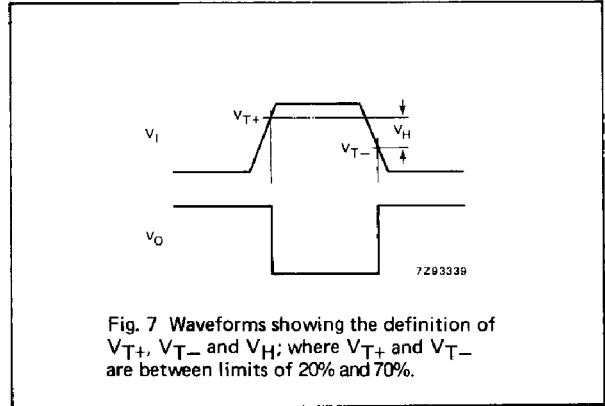

Fig. 7 Waveforms showing the definition of V_{T+} , V_{T-} and V_H ; where V_{T+} and V_{T-} are between limits of 20% and 70%.

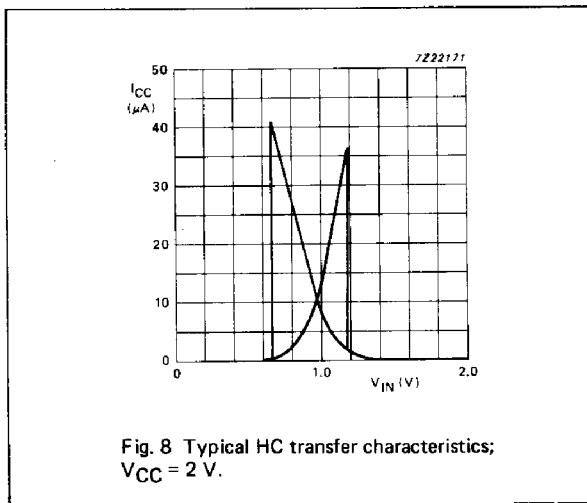

Fig. 8 Typical HC transfer characteristics; $V_{CC} = 2 \text{ V}$.

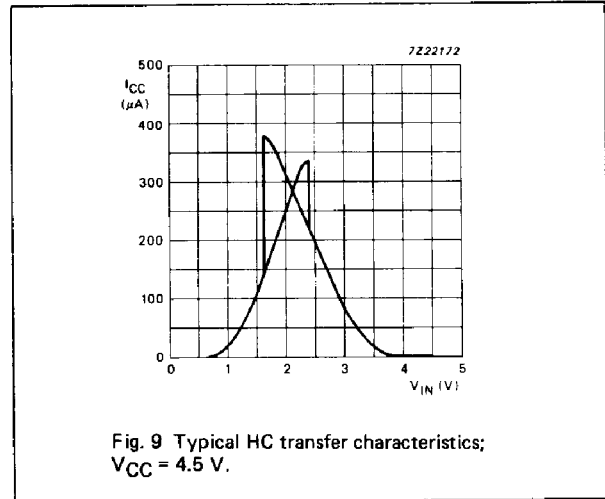

Fig. 9 Typical HC transfer characteristics; $V_{CC} = 4.5 \text{ V}$.

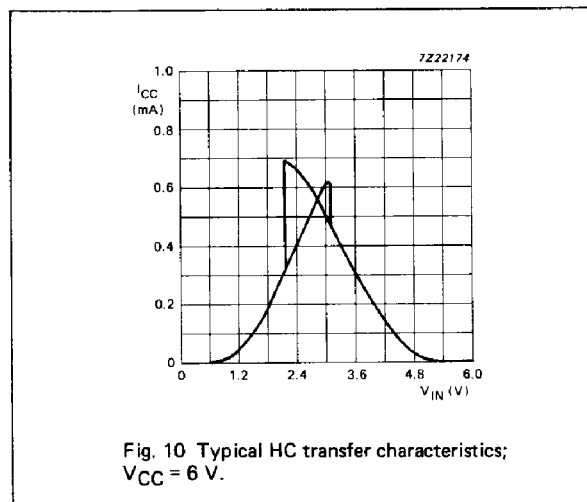

Fig. 10 Typical HC transfer characteristics; $V_{CC} = 6 \text{ V}$.

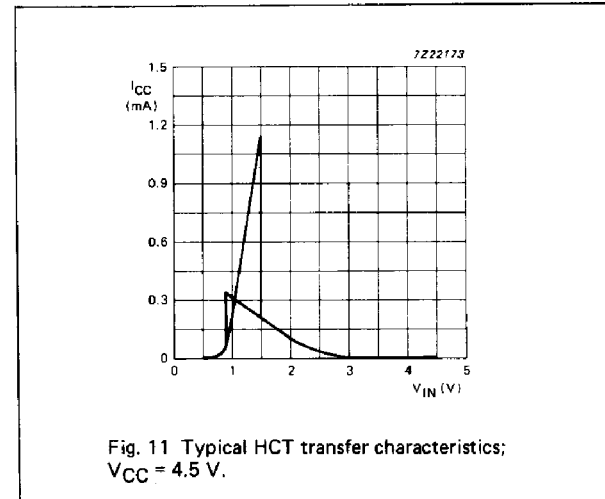
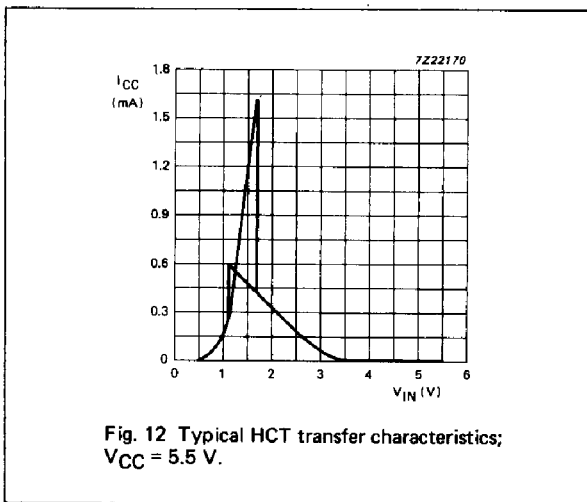
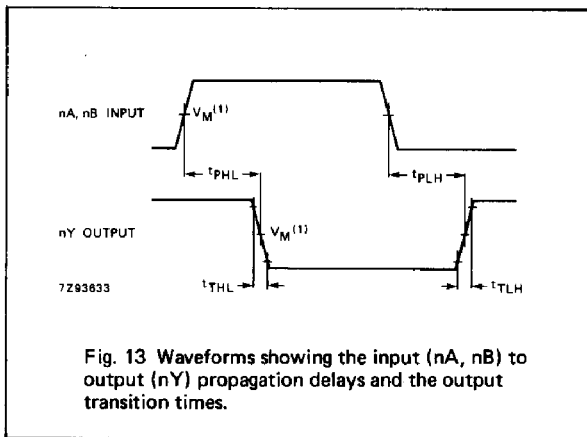

Fig. 11 Typical HCT transfer characteristics; $V_{CC} = 4.5 \text{ V}$.

TRANSFER CHARACTERISTIC WAVEFORMS (Cont'd)



AC WAVEFORMS



Note to AC waveforms

- (1) HC : $V_M = 50\%$; $V_I = \text{GND to } V_{CC}$.
- HCT: $V_M = 1.3 \text{ V}$; $V_I = \text{GND to } 3 \text{ V}$.

APPLICATION INFORMATION

The slow input rise and fall times cause additional power dissipation, this can be calculated using the following formula:

$$P_{ad} = f_i \times (t_r \times I_{CCa} + t_f \times I_{CCa}) \times V_{CC}$$

Where:

- P_{ad} = additional power dissipation (μW)
- f_i = input frequency (MHz)
- t_r = input rise time (ns); 10% – 90%
- t_f = input fall time (ns); 10% – 90%
- I_{CCa} = average additional supply current (μA)

Average I_{CCa} differs with positive or negative input transitions, as shown in Figs 14 and 15.

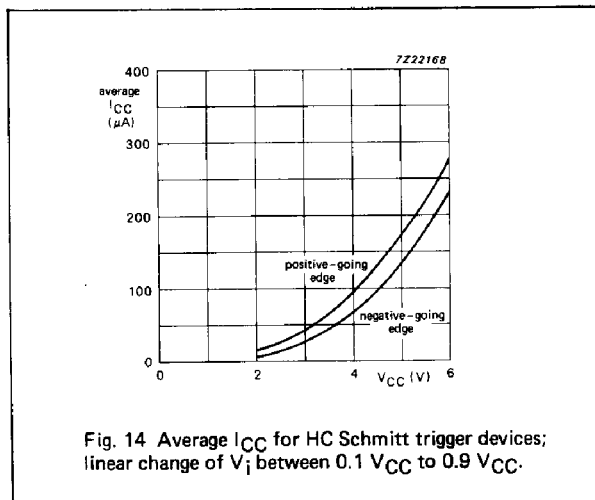

Fig. 14 Average I_{CCa} for HC Schmitt trigger devices; linear change of V_i between $0.1 V_{CC}$ to $0.9 V_{CC}$.

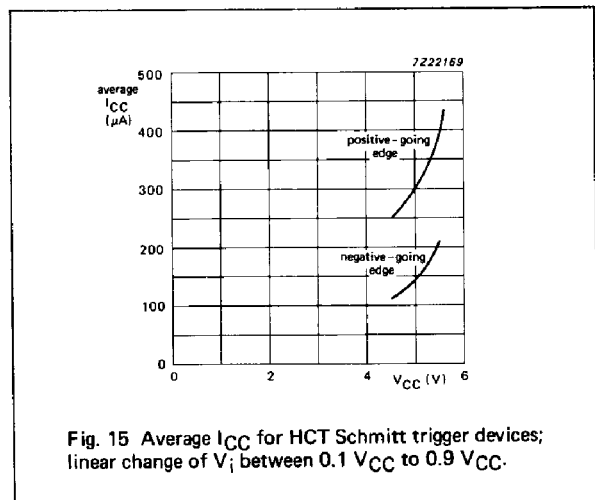

Fig. 15 Average I_{CCa} for HCT Schmitt trigger devices; linear change of V_i between $0.1 V_{CC}$ to $0.9 V_{CC}$.

HC/HCT132 used in a relaxation oscillator circuit, see Fig. 16.

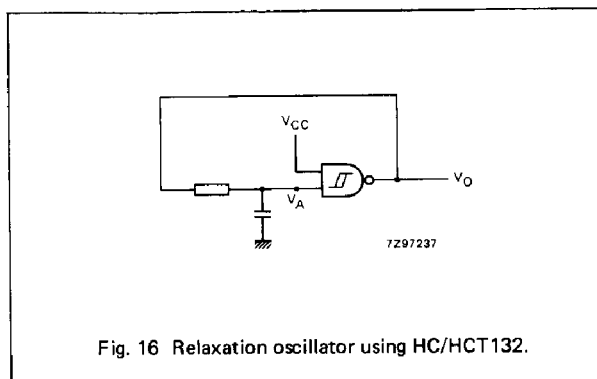

Fig. 16 Relaxation oscillator using HC/HCT132.

Note to Fig. 16

$$HC : f = \frac{1}{T} \approx \frac{1}{0.8 RC}$$

$$HCT : f = \frac{1}{T} \approx \frac{1}{0.67 RC}$$

Note to Application information

All values given are typical unless otherwise specified.